

MAINTENANCE OPERATIONS

Praktika QL-04(K) turnstile

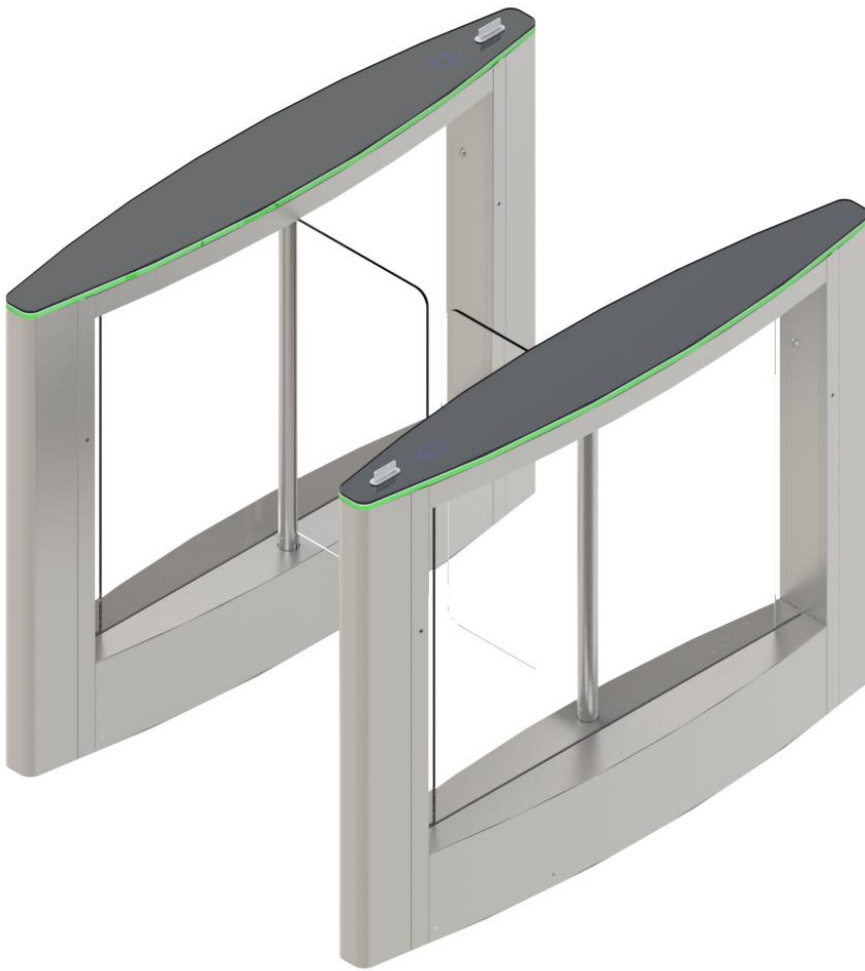

Content

1. General information	4
2. Conditions for maintenance	5
3. Partial disassemble of the speedgate	5
4. Checking speedgate parts	6
5. Speedgate lubrication	9
6. Assembling and operation checking of the speedgate	9

1. General information

1.1. During operation of the speedgate in order to maintain efficiency and to ensure calculated lifetime the maintenance operation of the speedgate shall be carried out periodically, including the warranty period (hereinafter MO).

1.2. MO shall be performed once in 6 months. Should there be any failure MO should be performed immediately after repair works.

1.3. During MO it is recommended to carry out the work by two qualified mechanical and electrical engineers, acquainted with the manual.

1.4. MO includes the following scope of work: partial disassemble of the speedgate, cleaning of load-bearing frame, checking of parts and units fixation, lubrication of subject to wear parts of actuating device, checking of belt tension, setting the dismantled parts and a general inspection of the speedgate.

2. Conditions for maintenance

CAUTION! It is strictly forbidden to carry out work with powered speedgate. Failure to follow these safety requirements could result in damage to human life and health, total or partial loss of product workability and (or) auxiliary equipment.

CAUTION! It is not recommended to adjust the limitation units of solenoid stroke, Hall sensor bracket and spring tension. These components are adjusted at the factory. Violation of these adjustments may lead to failures of the whole electromechanical system.

3. Partial disassemble of the speedgate

3.1. Turn off speedgate power supply and disconnect it from the electrical network.

3.2. In order to obtain access to necessary units of speedgate remove base cover by unscrewing the M4 screws (Fig. 1).

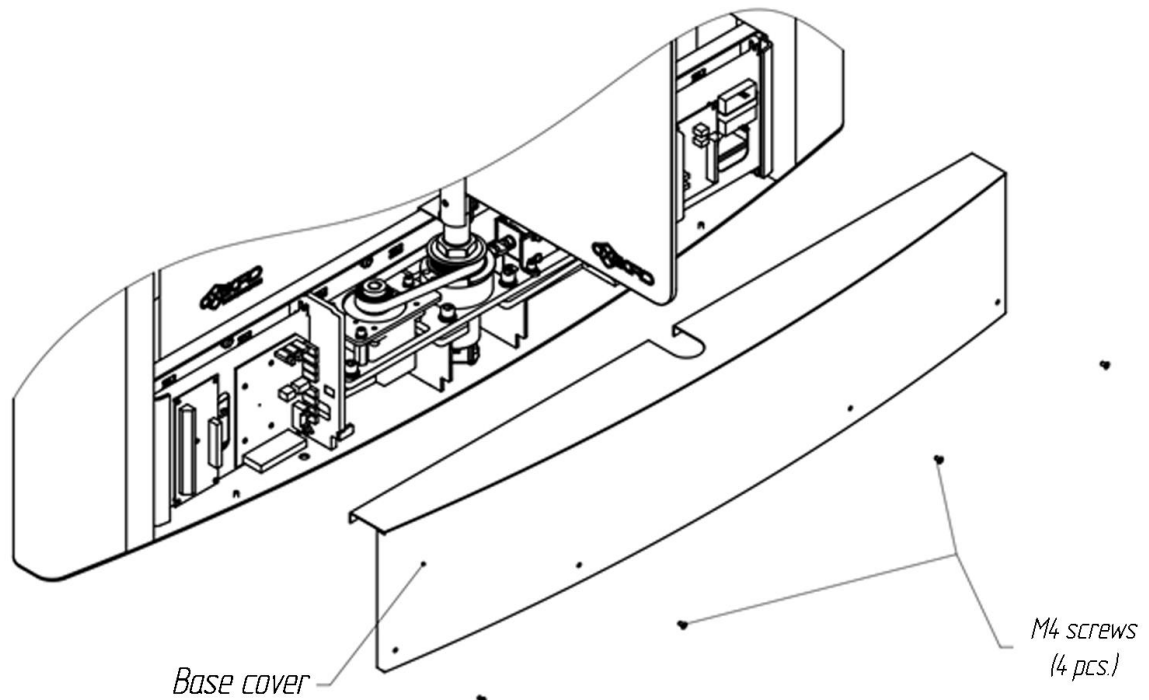

Fig.1

4. Checking speedgate parts

- 4.1. Clean the load-bearing frame from contamination.
- 4.2. Check that all cables are securely connected.
- 4.3. If necessary check and tighten the screw joints of speedgate:
 - fixation of speedgate housing to the base;
 - fixation of wings on brackets;
- 4.4. Check the condition of the toothed belt and its tension (Fig. 2). Correctly tensioned belt should be rotated through an angle of 45° from the fingers effort (1.5-2.0 kg / 15-20 H) (Fig. 3).

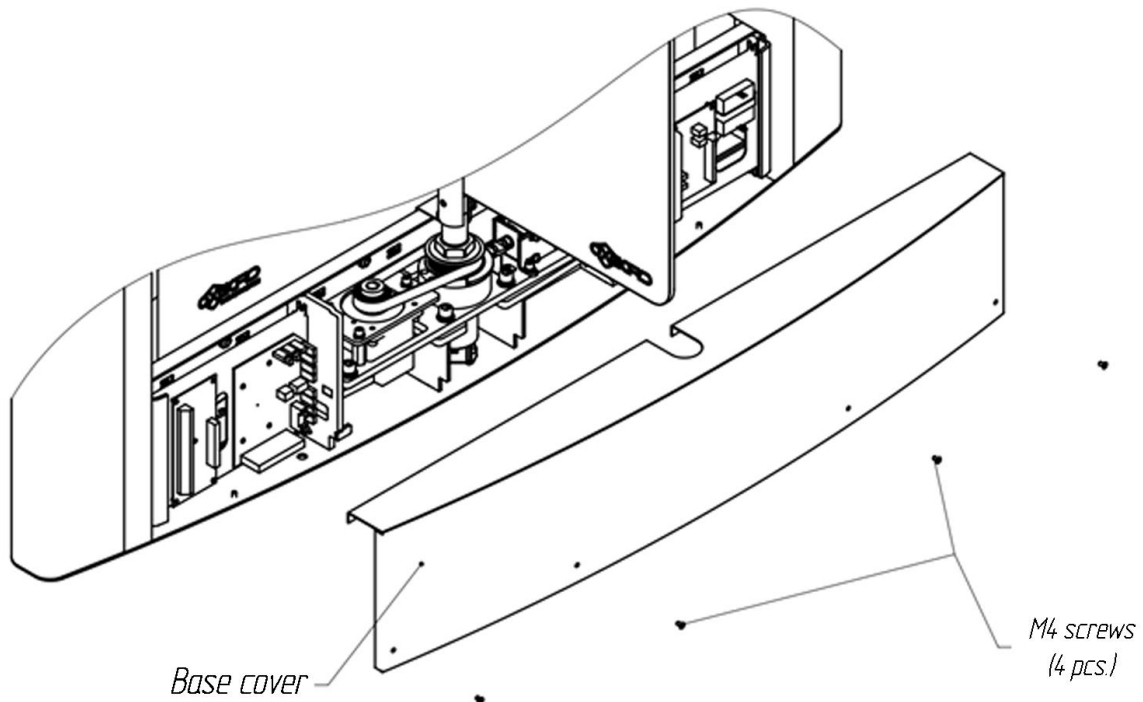

Fig.2

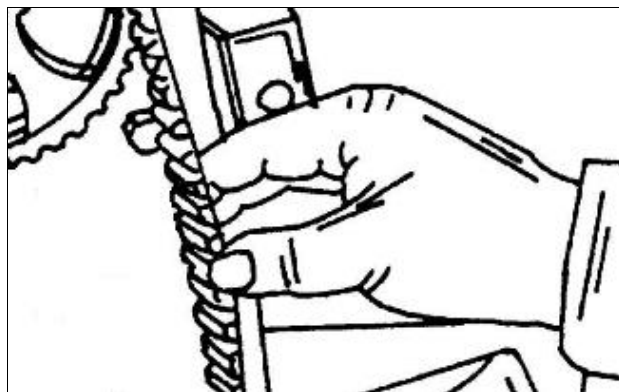

Fig. 3

The belt tension can be changed by moving the motor frame on right/left (Fig. 4).

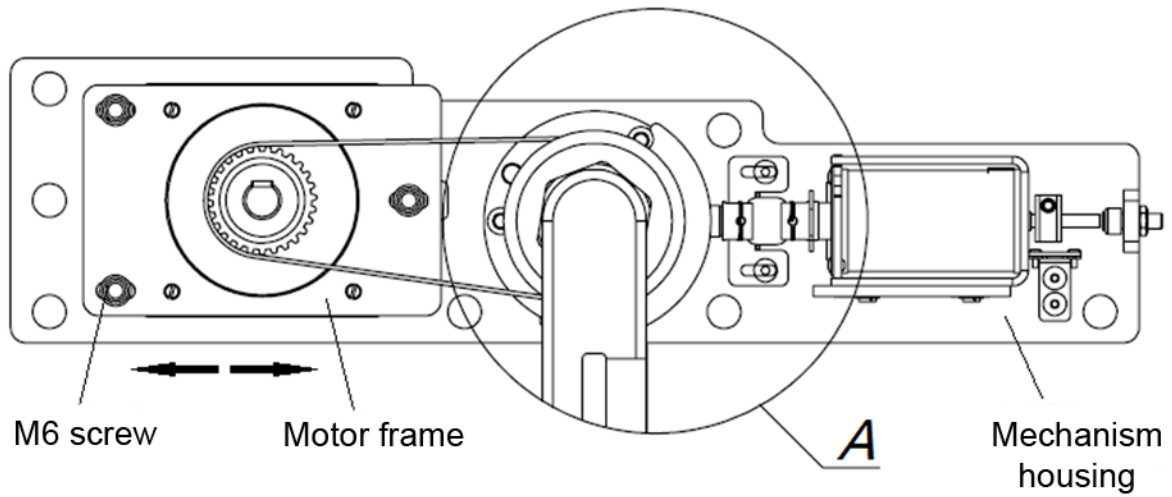

Fig.4

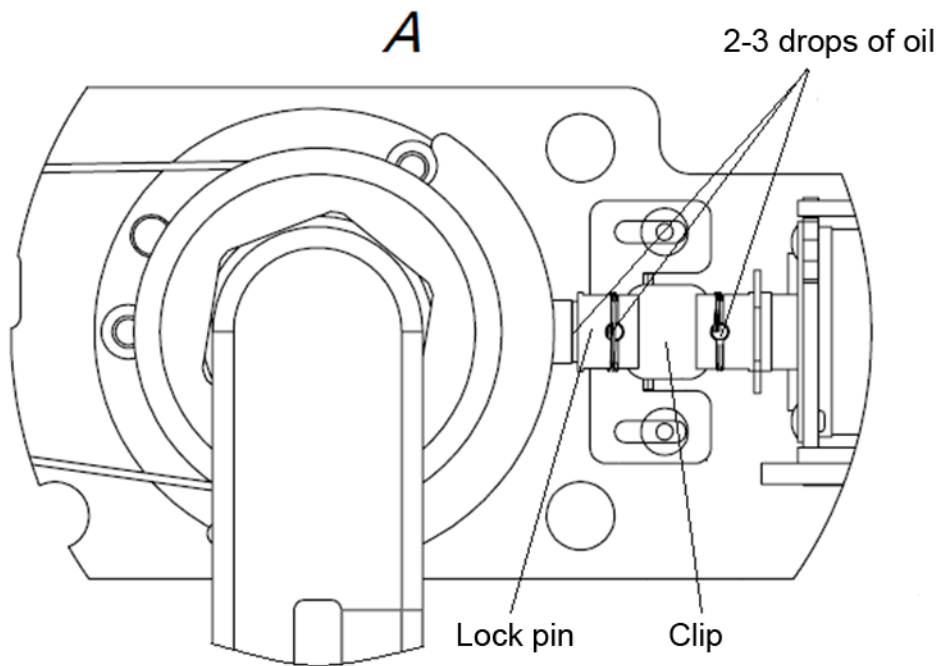

Fig. 5 Speedgate housing

5. Speedgate lubrication

5.1. Lubrication is made with 2 - 3 drops of engine oil (viscosity grade 5W-20).

5.2. Clips and lock pin between the lock and actuating device should be lubricated (Fig. 5, type A).

6. Assembling and operation checking of the speedgate

6.1. If any faults or defects are found out during MO it is advised to contact our service department for advice, contact details are available online:

www.oxgard.com

6.2. Reassemble the speedgate in reverse order.

6.3. Turn on the speedgate and check functionality.

6.4. If there is no extraneous noise or any abnormality in the speedgate work it is ready for operation.

PRODUCT IS CERTIFIED

Voltage: 12V DC

Current: 5A

Importer: VZR System OU

Tulika 19, Tallinn 10613

+ 372 5844 4957

e-mail:

info@vzrsystem.ee

www.vzrsystem.ee

Manufacturer:

«Vozrozhdenie»

66, Sofiyskaya str. 192289

St. Petersburg, Russia

Tel. 8(812)706-95-31

e-mail: sales@oxgard.com

www.oxgard.com



ISO 9001:2008



ООО "Возрождение"
192289 Санкт-Петербург
ул. Софийская, д.66
тел./факс +7 (812) 336 15 94
www.oxgard.com
info@oxgard.com