

Installation
guidelines

Praktika T-01 turnstile





Contents

1. Basic specifications	5
2. Product design	6
3. Safety requirements.....	8
4. Installation of turnstile	9
4.1. Required equipment	9
4.2. Installation of turnstile.....	10
5. Connecting turnstile	13
5.1. Connecting power supply.....	14
5.2. Connecting RC panel.....	15
5.3. Connecting access control system (optional).....	16
5.4. Connecting RC panel to ACS controller.....	18

List of abbreviations

PS	– power supply
RC	– remote control
ACS	– access control system
OD	– operating device (turnstile)
NC	– normally connected
NO	– normally opened

1. Basic specifications

Table 1 Basic specifications

Description	Turnstile	RC panel
Dimension (HxWxL), (mm) - operational state - collapsed arms	1200x7900x850 1200x200x350	107x107x25
Weight, kg	44	0,5
Temperature range, 0C - operation - transportation and storage	+1...+40 +1...+40	+1...+40 +1...+40
Atmosphere relative humidity, no more than %	80	80
Passage width, mm	500	
Throughput, people per minute	30	
Lifetime, years	8	8

Table 2 Electrical specifications

Description	Turnstile	RC panel
Supply voltage, V: - nominal - working	12,0 10,8...13,2	12,0 7,5...15
Average current in standby mode * A	0,25	
Average current operational mode * A	1,5	
Maximal current *A (during “antipanic” mode activating)	5,0	

*- values mentioned at a nominal supply voltage

The manufacturer reserves the right to change the packaging, specifications and appearance without notice

2. Product design

Turnstile housing

Turnstile housing and arms are made of brushed stainless steel. In the middle part of the housing there is a removable cover with lock for quick access to the motherboard where PS, RC and ACS cables are connected. In the lower part there are holes for cable routing and base cover concealing the fixation of turnstile to the floor (Fig. 1).

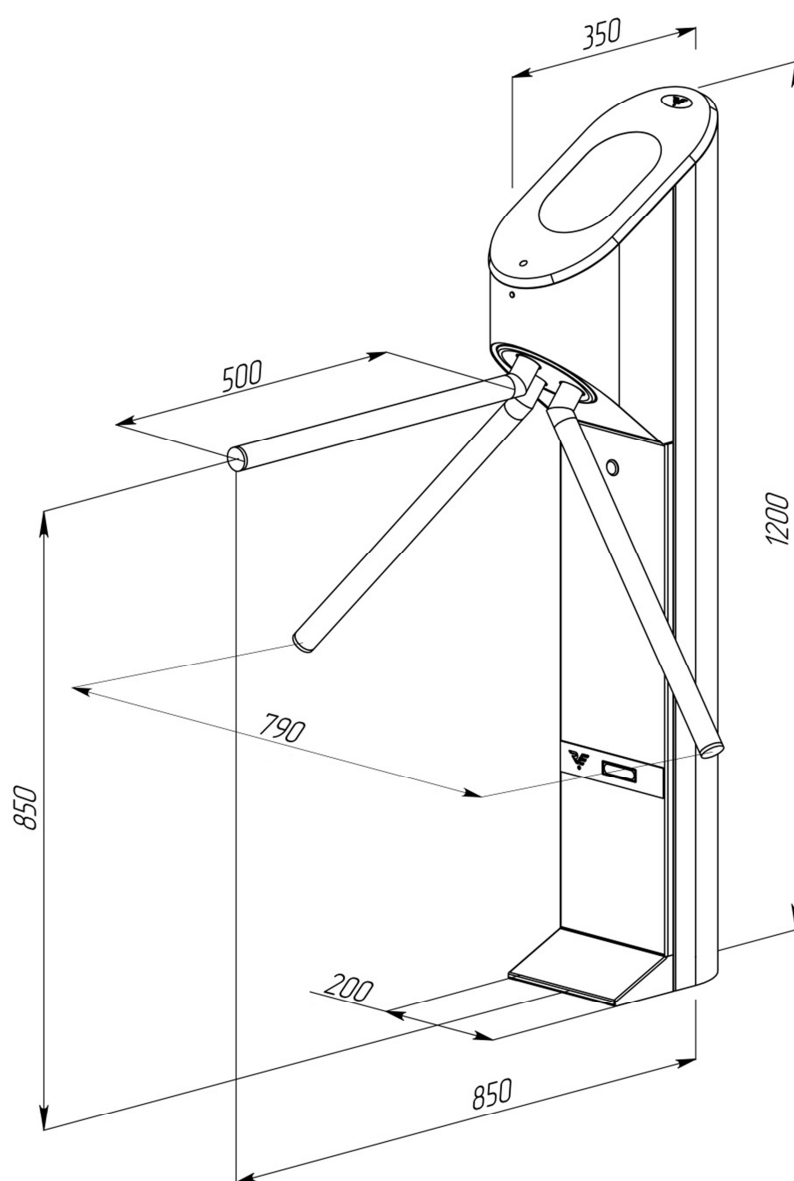

Fig. 1 General view of turnstile

LED panel

Display panel of the turnstile is made of artificial stone with an insertion made of acrylic glass. Turnstile operating modes are displayed on the panel in the form of mnemonic signs depicting authorization and non-authorization of passage (Fig. 2).

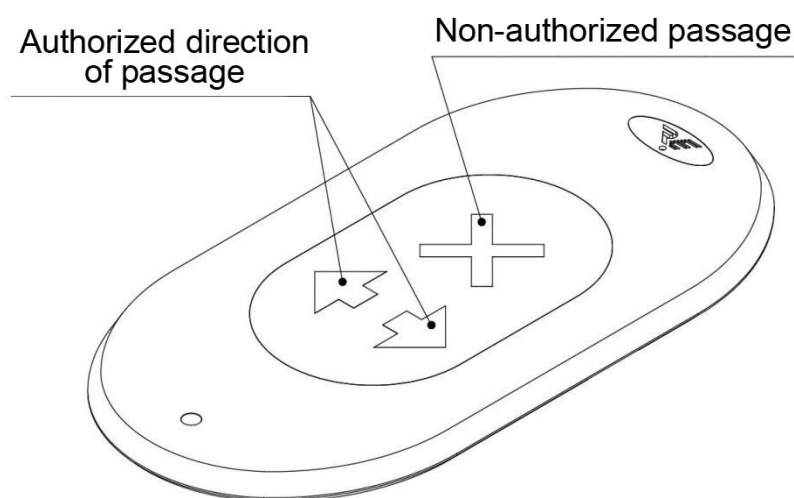

Fig. 2 General view of display panel

Remote Control Panel

The housing of RC is made of polished stainless steel. On the front side there are control buttons and LED indicators of RC operational modes (Fig. 3). The standard supplied cable is 5 m long.

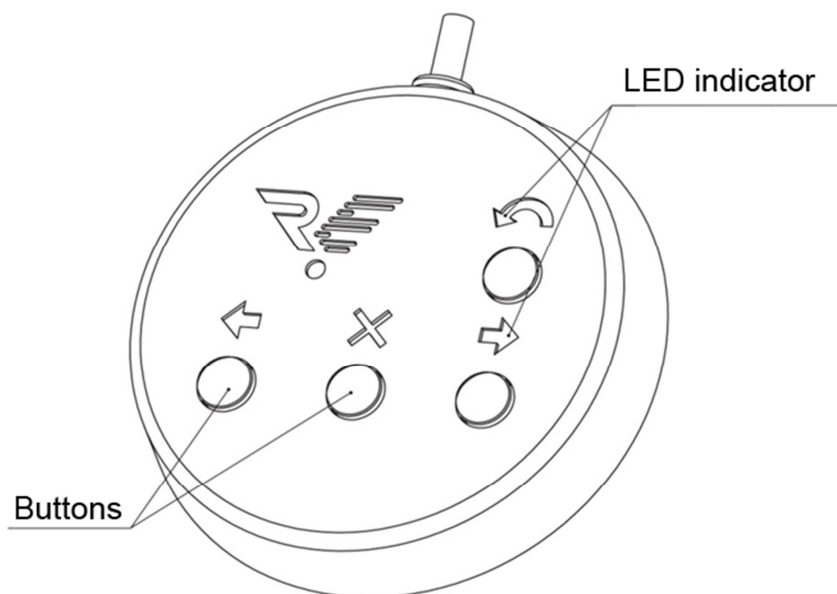

Fig. 3 General view of remote control panel

3. Safety requirements

CAUTION! Failure to comply with the safety requirements specified in this section may result in damage to human life and health, total or partial loss of workability of products and (or) auxiliary equipment.

CAUTION! The producer disclaims any liability for damage to human life and health, total or partial loss of workability of products and (or) auxiliary equipment for non-compliance of the safety requirements specified in this section, as well as terminate the product warranty.

IT IS NOT ALLOWED TO:

- Set the power supply inside the turnstile housing as this could lead to electric shock to persons;
- Set the turnstile other than dry and heated places;
- Impede or accelerate the turnstile arms during on/off “antipanic” mode;
- Apply chemically aggressive cleaning detergents as pastes and liquids.

4. Installation of turnstile

CAUTION: The turnstile should be installed securely to avoid swinging and (or) overthrow during operation. In case of installation on the low strength floors - take action to strengthen the floor at the installation site. Before checking operability of the turnstile carefully read this section of the Guidelines.

4.1. Required equipment

Tools used for turnstile mounting:

- electric perforator;
- 20mm diameter carbide drill for drilling holes in the floor for anchors (recommended anchor - SORMAT PFG LB 12-50);
- S10 wrench for hexagon socket head screws;
- slotted screwdriver;

- plumb line or level;
- steel liner for turnstile alignment
- round file
- side cutters

4.2. Installation of turnstile

CAUTION: When designing the mounting site of the turnstile take into account that rotation direction of arms will be counter-clockwise during "antipanic" mode.

4.2.1. Prepare a horizontal surface at the installation site of turnstile.

4.2.2. Prepare cable channel from the site to the installation site of PS, RC, as well as, if required, to the point of ACS and fire alarm connection.

4.2.3. Follow the layout (Fig. 4) prepare and drill 3 holes of 20mm diameter in the floor for anchors. Location of mounting holes according to the outer dimensions of the turnstile is shown in Appendix 3 (Fig. 11). Depth of the hole should exceed the length of the anchor for more than 5mm. Put anchors in the holes.

4.2.4. Cable routing is carried out through a hole 1 (Fig. 4) in the lower plate of turnstile. Cable conduit shall be prepared.

4.2.5. Open the box and unpack:

- turnstile;

- remote control panel with cable;
- base cover
- lock keys (2 pcs.).

4.2.6. Route cable of RC panel, cable of PS unit and, if provided, cables of FA and ACS into cable conduit.

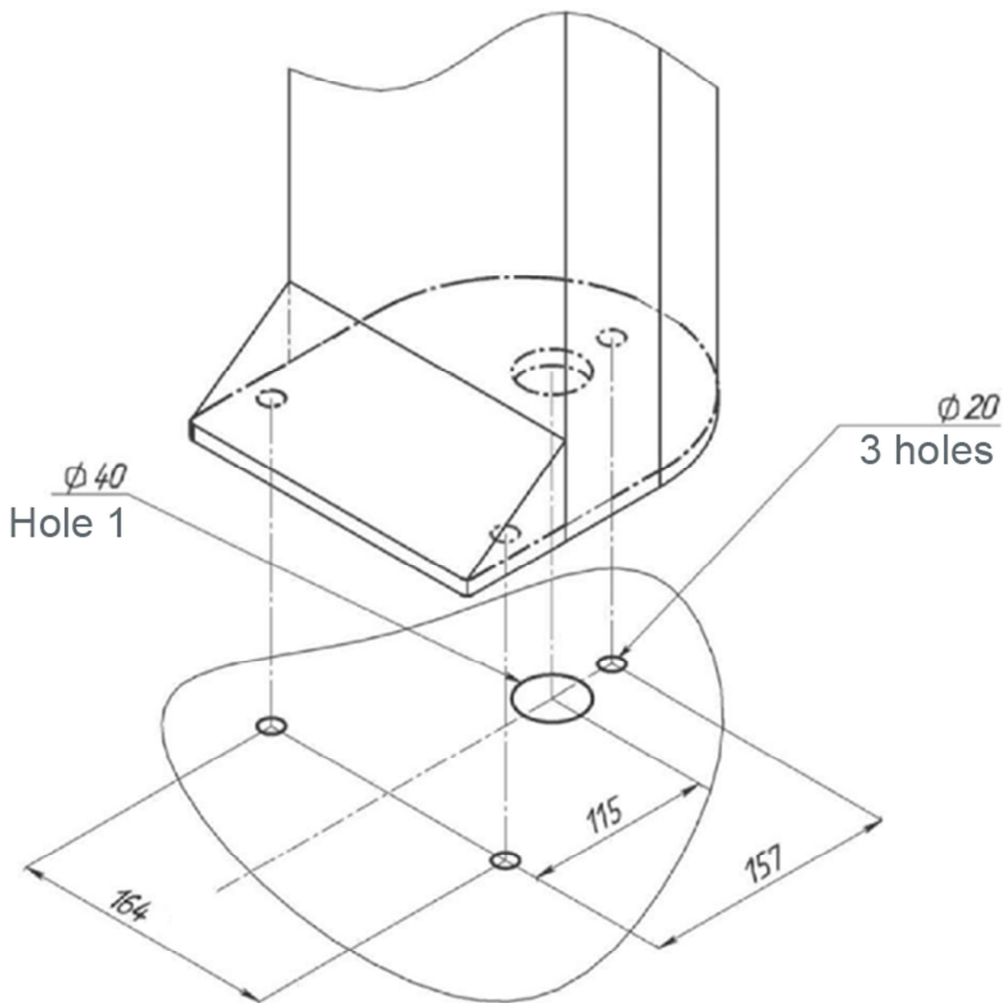

Fig. 4. Installation dimensions

4.2.7. Set the turnstile on the prepared site (Fig. 4). Open the lock and remove the hatch (1, Fig. 5). Route cables of RC, PS and if necessary, ASC and FA into the housing. Cable routing shall be performed via hole 1 in lower plate of the turnstile. Secure cables with cable ties.

Lock

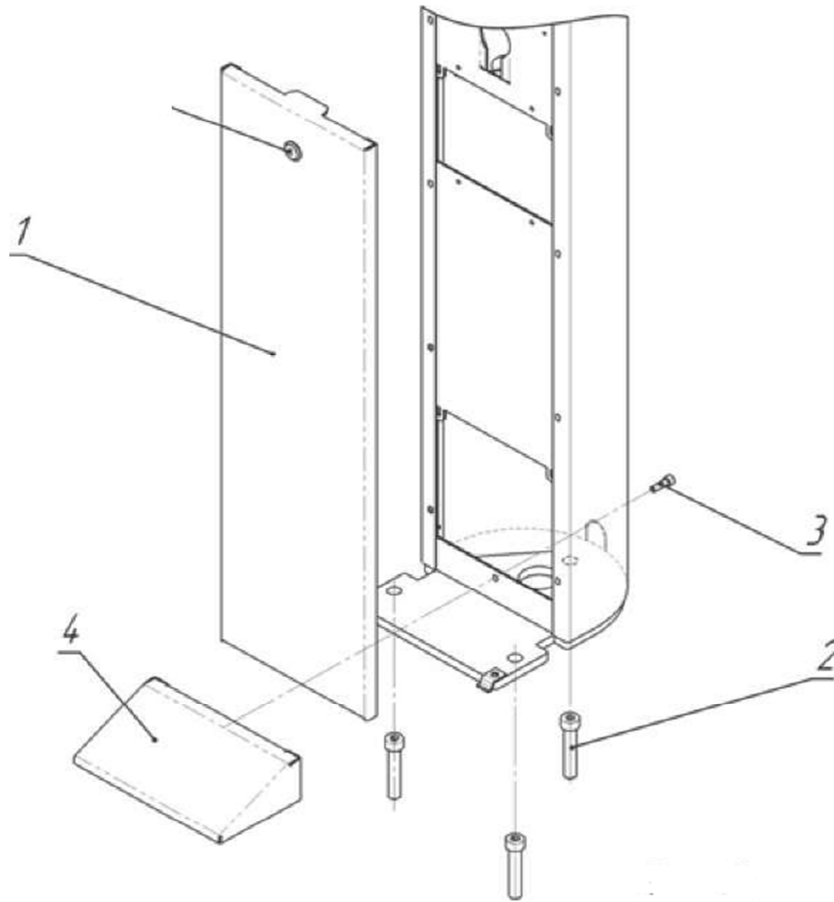

Fig. 5. Installation diagram of turnstile

4.2.8. Align holes in the lower plate of the turnstile together with anchors in the floor. Check the vertical installation in 2 planes. If necessary, use appropriate steel underlayers for proper installation of the turnstile. Fix the housing of the turnstile with 3 screws M12 (2, Fig. 5), tightening them to the corresponding anchors by using a S10 wrench with internal hexagon. Set the base cover (4, Fig. 5) and secure it with the screw M6 included in the delivery set (3, Fig. 5). Install the hatch (1, Fig. 5) at its original position and close the lock.

4.2.9. Remove protective film from the housing of the turnstile.

5. Connecting turnstile

Connection of RC, PS and ACS is performed with the use of motherboard. In order to do it, open turnstile hatch (1, Fig. 5) with a key. Fig. 6 shows the location of motherboard in the housing.

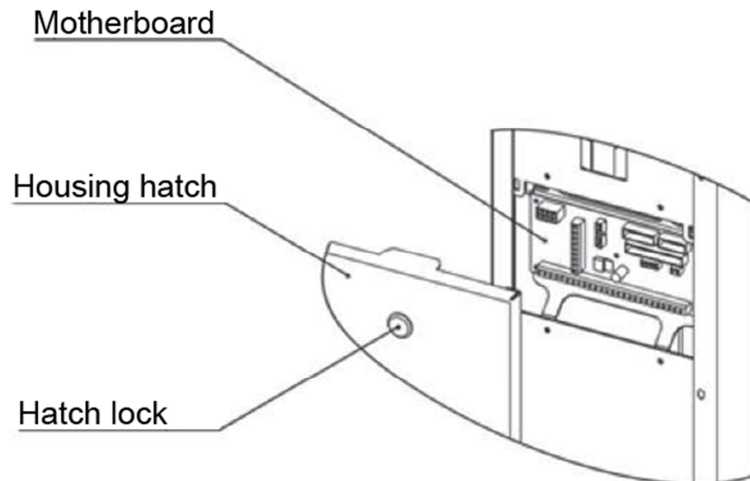

Fig. 6 Location of motherboard

Fig. 7 depicts the motherboard and connectors for PS unit, RC panel, ACS and FA.

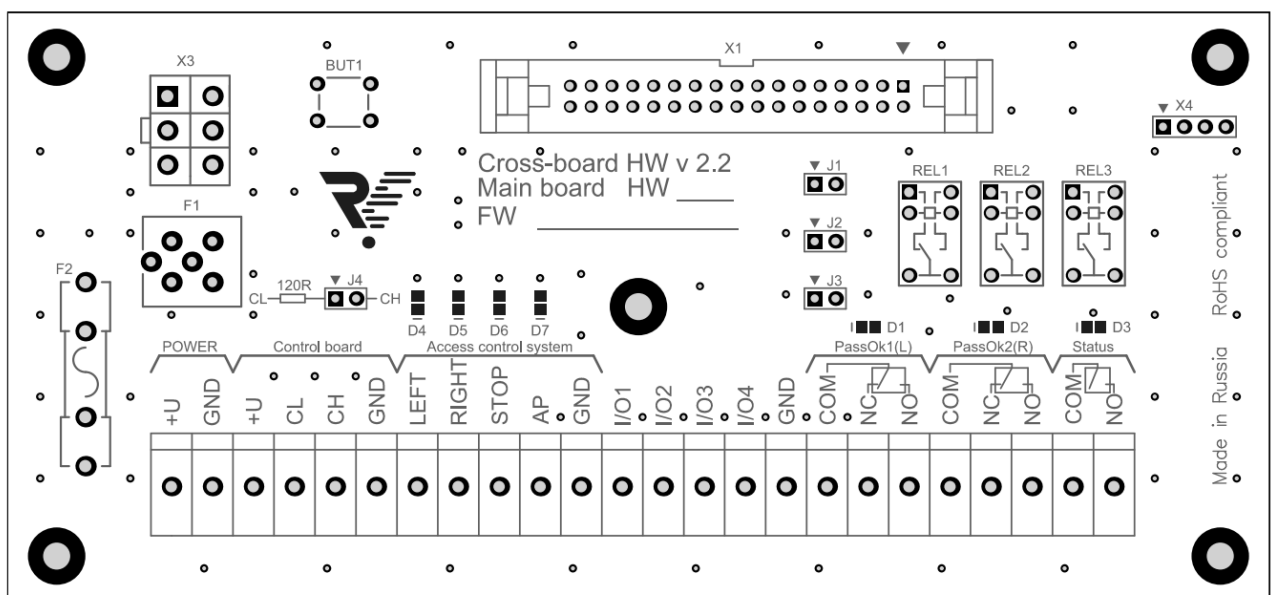

Fig. 7 General view of motherboard

Table 3 Operating modes of turnstile

The position of jumpers	Operating mode of turnstile
J1 removed	Pulse mode (see Article 5.3.)
J1 installed	Potential mode (see Article 5.3).
J2 installed	Turnstile does not respond to RC panel commands. Status of buttons is transmitted to I / O1 ... I / O4 outputs (see Article 5.4)
J2 removed	Turnstile is controlled by remote control panel. Status of the buttons is transmitted to I / O1 ... I / O4 outputs (see Article 5.4)

- Jumper J3 is not used
- Jumper J4 is used to establish the normal operation of CAN2.0 bus. See Appendix 1.

5.1. Connecting power supply

CAUTION! Do not use power supply units with an output current less than 5A.

Do not install the power supply unit at a distance more than 25 meters from the turnstile.

CAUTION! Do not use power cable with cross-section less than 1.5 mm² for connection. When the length of the power cable is more than 10 m it is recommended to use a cable with 2.5 mm² cross-section.

Turnstile is powered by 12V DC voltage. Maximum consumption (5A) is observed during "antipanic" mode when arms are folding. PS unit shall be selected on the basis of these parameters. Also note that an increase in the length of the supplied cable increases the voltage drop.

Install the PS unit in a place with easy access for operator. Connect the power supply to the POWER contact set on the motherboard. Connect (+) and (-) contacts of PS unit to (12V) and (GND) terminals respectively.

Make sure the cables are securely connected. Install the hatch and close the lock.

5.2. Connecting RC panel

RC panel is connected to a Control Board contact set on motherboard. Marking of contacts: 12V, CL, CH, GND.

Connection is made according to contact marking shown in Table 4.

Table 4 Marking of RC contacts

Contacts marking	Wire color
12V	Red
CL	Yellow
CH	Green
GND	Blue

5.3. Connecting access control system (optional)

ACS controller is connected to AccessControlSystem contact set on motherboard. Marking of contacts: LEFT, RIGHT, STOP, AP, GND. Contact assignment is shown in Table 5

Table 5. ACS contacts assignment

Contacts marking	Contacts assignment
LEFT, RIGHT	single pass left / right (lowest priority)
STOP	non-authorized pass (mode "Stop") (medium priority)
AP	arms folding ("antipanic") (highest priority)
GND	common contact

Inputs for connecting of ACS differ on priorities:

AP input has the highest priority. As long as this input is closed GND contact, arms of the turnstile are collapsed and the turnstile does not respond (!!!) to other signals;

STOP input has the medium priority. When the input is closed on GND contact the turnstile switches to "Stop" and does not respond to other effects, except AP.

LEFT and RIGHT inputs have the same low priority and include a single passage in one direction or another. If both inputs are closed, passage is allowed in that direction the input which was closed first. If passage was not performed the turnstile will move to "Stop" mode automatically within 5 seconds.

CAUTION (!) In case of closure of one of STOP (or) AP inputs - commands from the remote cannot be accepted, i.e. ACS has a higher priority.

AP and STOP inputs operate only in a potential mode, i.e. as long as the input is closed on GND contact the turnstile operates in the corresponding mode. After contacts opening - turnstile switches to the "Stop" mode irrespective to the mode of operated that was used before ACS operation.

LEFT and RIGHT inputs can operate both in the potential and in pulse mode (responding upon GND contact closure). Pulse mode is set on default.

In order to switch to a potential mode set J1 jumper (Fig. 7). In this case the mode of left / right passage turns on only during the control signal to LEFT / RIGHT inputs. Mode of free passage can be set by control signals to both inputs simultaneously. Priorities of LEFT and RIGHT inputs at the switch to the pulse mode remain unchanged.

Motherboard contains two relay outputs for ACS operating on the principle of "dry contacts» - Pass Ok1 and Pass Ok2. NO and COMM - normally open connection, NC and COMM - normally closed connection. Activation of one of the contact sets suggests the passage in the corresponding direction (PassOk1 - right, PassOk2 - left). "Dry contact" closes / opens when arms rotate at an angle of 60 degrees and return to the starting position when passage is completed.

Motherboard contains relay output for ACS operating on the principle of "dry contacts» - Status. NO and COMM - normally open connection, its

contacts close when the turnstile switches to "AP" and D3 LED indicator lights up.

Also the motherboard contains the following LED indicators:

D4 indicates a signal to the «LEFT» input.

D5 indicates a signal to the «RIGHT» input.

D6 indicates signal to the «STOP» input.

D7 signals a signal to the «AP» input.

Jumper J4 shall be installed. It is used to connect a 120 Ohm resistor to CAN 2.0 bus to ensure its normal operation. If using two remote controls J4 shall not be installed, because 120 Ohm resistors are installed on CL and CH contacts in remote control panels.

5.4. Connecting RC panel to ACS controller

In some cases RC shall be connected directly to the ACS controller as the passages allowed from the remote (without controller) are regarded by the system as a "forced entry".

To use this connection pattern of turnstile J2 jumper shall be set on the motherboards (Fig. 7). When J2 jumper is set the turnstile does not respond to remote control panel commands but only transmits their status to contacts of I / O1 ... I / O4 terminal boards (Fig. 7) which are open collector outputs. Contacts assignment is shown in Table 6. The numbering of the remote control buttons is shown in Fig. 8. The maximum output current for this set of contacts is 150 mA, maximum voltage rating is 24 V.

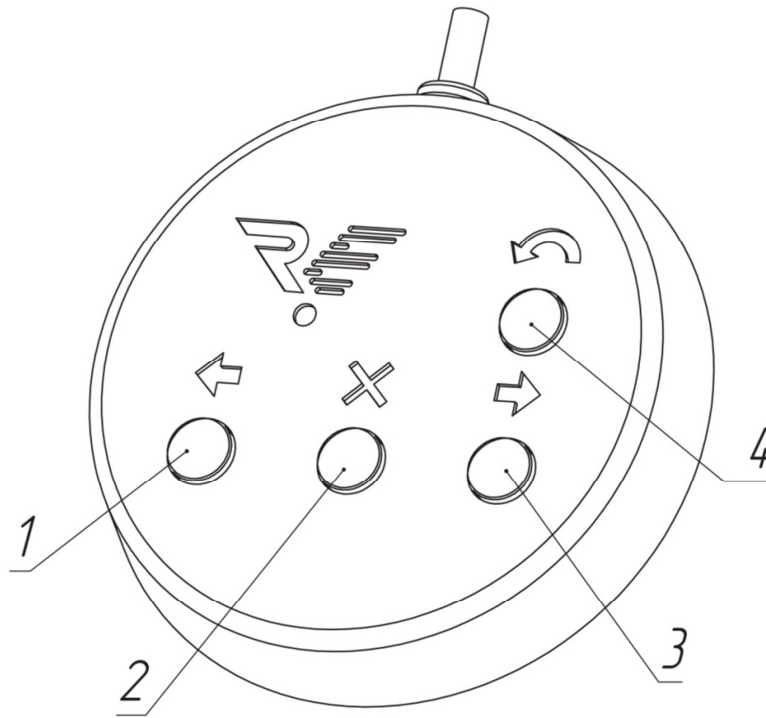

Fig. 8 Numbering of RC panel buttons

Table 6. I/O contact set assignment

Contacts marking	Contact assignment
I/O1	"Left" button status (1,0)
I/O2	"Right" button status (3,08)
I/O3	"Stop" button status (2, Fig.8)
I/O4	Button "Antipanic" status (4,0)

I / O1 ... I / O3 outputs show the current state of RC panel buttons, i.e. transistor is opened by pressing the corresponding button. I / O4 output changes its state to the opposite every time the "antipanic" button is pressed.

I / O1 ... I / O4 outputs can be connected both directly to the ACS controller or via relay. When using the relay it is **necessary (!)** to connect diode in parallel with the relay coil (Fig. 9).

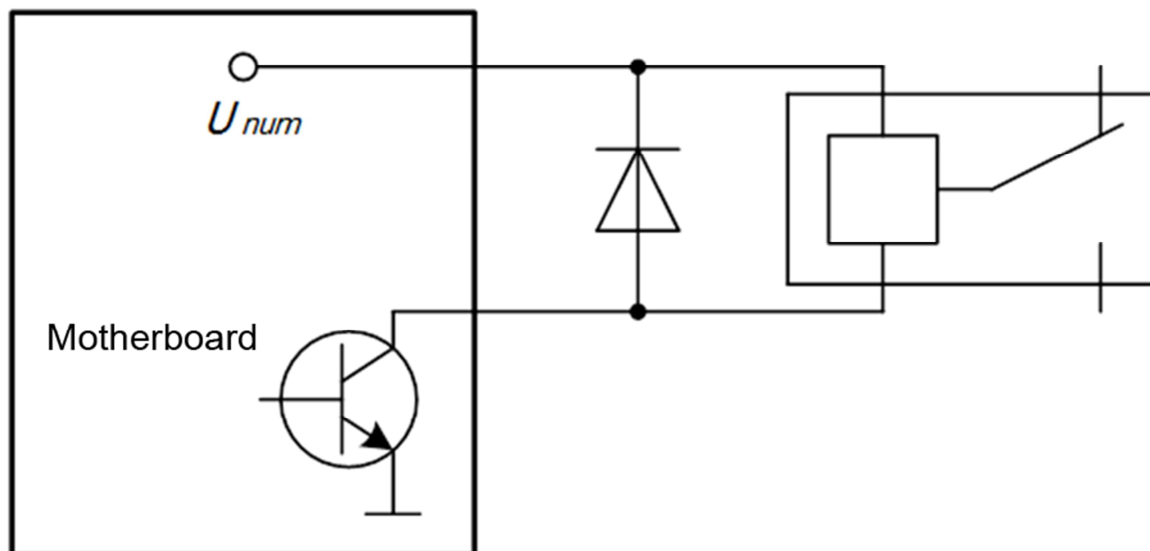

Fig. 9 Connection of diode in parallel with the relay coil

Connection of RC panel to ACS controller is shown in Fig. 10. In this case the controller controls the turnstile via "Left", "Right" and "Stop" contacts, and the contact "antipanic" is turned on and off with the RC panel. Please note that when the RC panel is connected via ACS controller it is impossible to use turnstile modes which are set by the combination of the RC panel buttons (except for the free passage in the potential control mode. See section 5.3 of Manual). In this case ACS controls these operation modes.

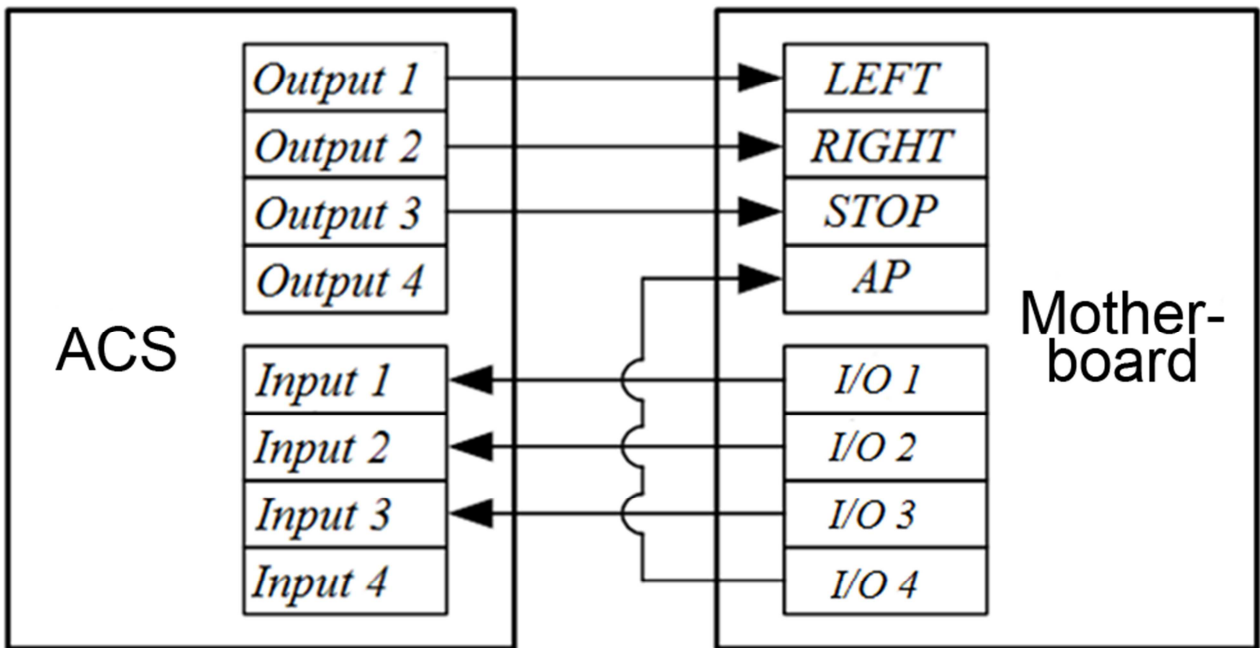

Fig. 10 Connection pattern of RC panel to ACS controller

Appendix 1. Summary of the data bus CAN2.0

The RC panel uses modern CAN2.0 noise-immune bus. According to CAN2.0 standard signal cable length can exceed one kilometer, however correct operation on these distances depends on many factors. Always use Cat5e or Cat6 twisted pair at distances exceeding 25 meters. The total electrical resistance of DC power supply wire shall not exceed 50 ohms. If this requirement cannot be met an additional 12V / 100mA power supply unit (minimum operating voltage of PU - 7.5V). There are 3wires - CL, CH, GND - enough for the correct operation of the turnstile. In this case the power supply wire from the PU to the turnstile is not required. See Fig. 18. Two RC panels can be connected to the same turnstile.

An important feature of the CAN2.0 bus is the use of 120 Ohm resistors at the ends of the bus. The standard RC panel is equipped with such resistor on default. If you use one RC panel it is recommended to connect an additional (second) 120 ohm resistor mounted on the motherboard to CL and CH terminals. It is connected with the use of J4 jumper.

It is not required, however, in case of connection of two RC panels, because required 120 ohm resistors are already installed at the ends of the bus (in RC panels). J4 jumper can be taken off.

A special RC panel is required to operate several turnstiles simultaneously. Standard RC is not appropriate for this purpose.

Appendix 2. Location of mounting holes in relation to overall dimensions of the turnstile

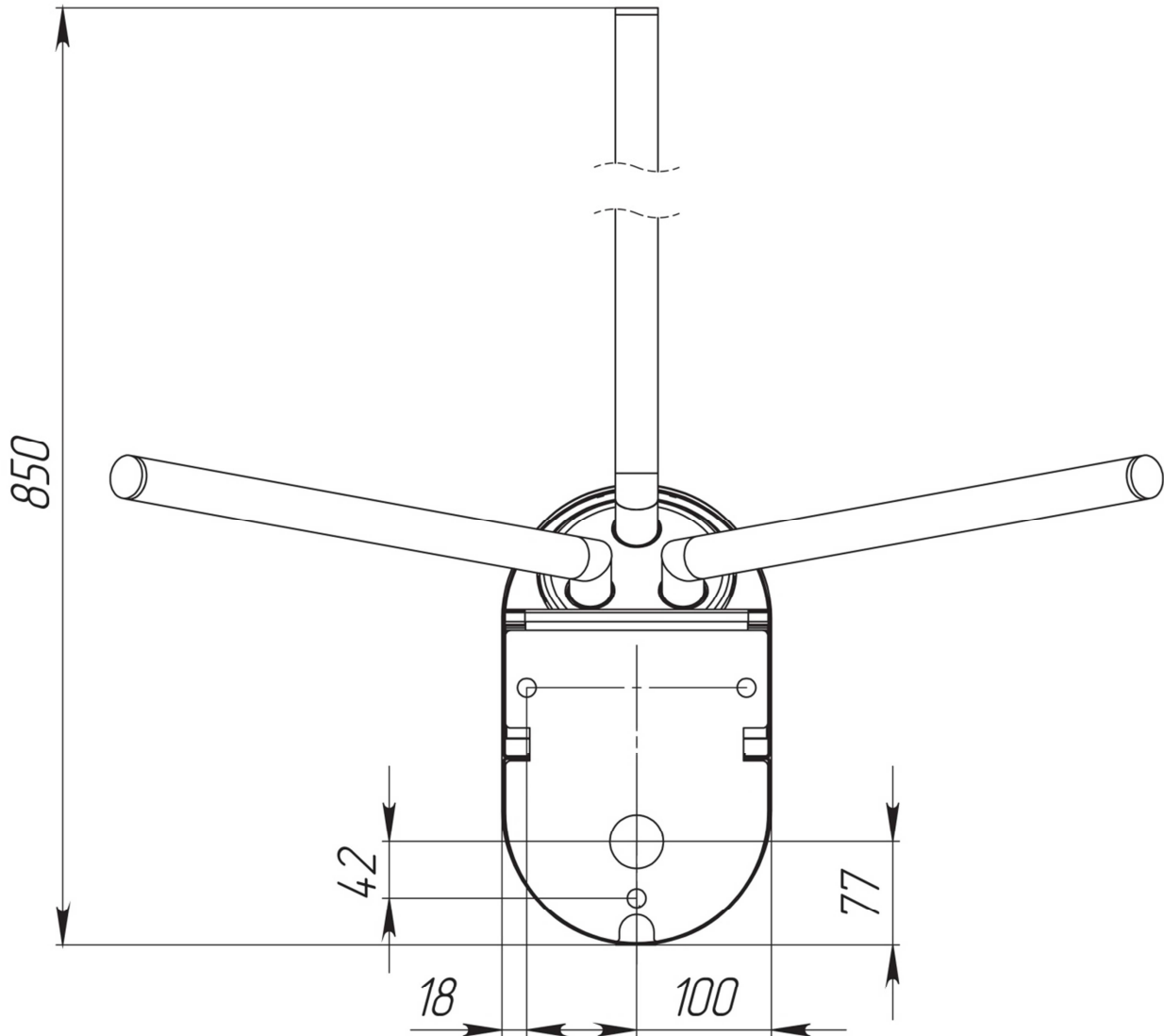

Fig. 11 Location of mounting holes in relation to overall dimensions of the turnstile



ООО "Vozrozhdenie"

192289 Saint Petersburg

Sofiyskaya st., 66

Tel./fax +7 (812) 366 15 94

www.oxgard.com

info@oxgard.com

