

Installation
guidelines

Praktika T-03(K) turnstile



Contents

1. Basic specifications	5
2. Product design	6
3. Safety requirements.....	9
4. Installation of turnstile	10
4.1. Required equipment	10
4.2. Installation of turnstile	11
5. Connecting turnstile	15
5.1. Connecting power supply.....	17
5.2. Connecting remote control panel	17
5.3. Connecting access control system (optional).....	18
5.4. Connecting RC panel to ACS controller.....	20
6. Connecting card collector	24
6.1. Card collector description	24
6.2. Connecting power supply.....	26
6.4. Connecting ACS controller	27
6.5. Installation of proximity card reader.....	30

List of abbreviations

PS	– power supply
FA	– fire alarm
RC	– remote control
ACS	– access control system
OD	– operating device (turnstile)
NC	– normally connected
NO	– normally opened

Turnstile firmware version FW v1.76

Card collector firmware version FW v1.52

1. Basic specifications

Table 1 Basic specifications

Description	Turnstile	RC panel
Dimension (HxWxL), (mm) - operational state collapsed arms	1505x1200x850 1505x1200x350	107x107x25
Weight, kg	132,0	0,5
Temperature range, 0C - operation - transportation and storage	+1...+40 +1...+40	+1...+40 +1...+40
Atmosphere relative humidity, no more than %	80	80
Passage width, mm	500	
Throughput, people per minute	30	
Card collector capacity (pcs.) **	More than 500	
Max. number of connected RC panels, pcs	2	
Lifetime, years	8	8

Table 2 Electrical specifications

Description	Turnstile	Card collector**	RC panel
Supply voltage, V: - nominal - working	12,0 10,8...13,2	12,0 8...18,0	12,0 7,5...15,0
Average current in standby mode * A	0,4	0,2	
Average current operational mode * A	1,5		
Maximal current * A	5,0	1,5	

*- values mentioned at a nominal supply voltage

**-optional

The manufacturer reserves the right to change the packaging, specifications and appearance without notice

2. Product design

Turnstile housing

Turnstile housing and arms are made of brushed stainless steel. Panels are made of tempered glass. The turnstile can be equipped with a card collector. In the middle part of the housing there is a removable cover with lock for quick access to the motherboard where PS, RC and ACS cables are connected. In the lower part there are holes for cable routing and base cover concealing the fixation of turnstile to the floor (Fig. 1).

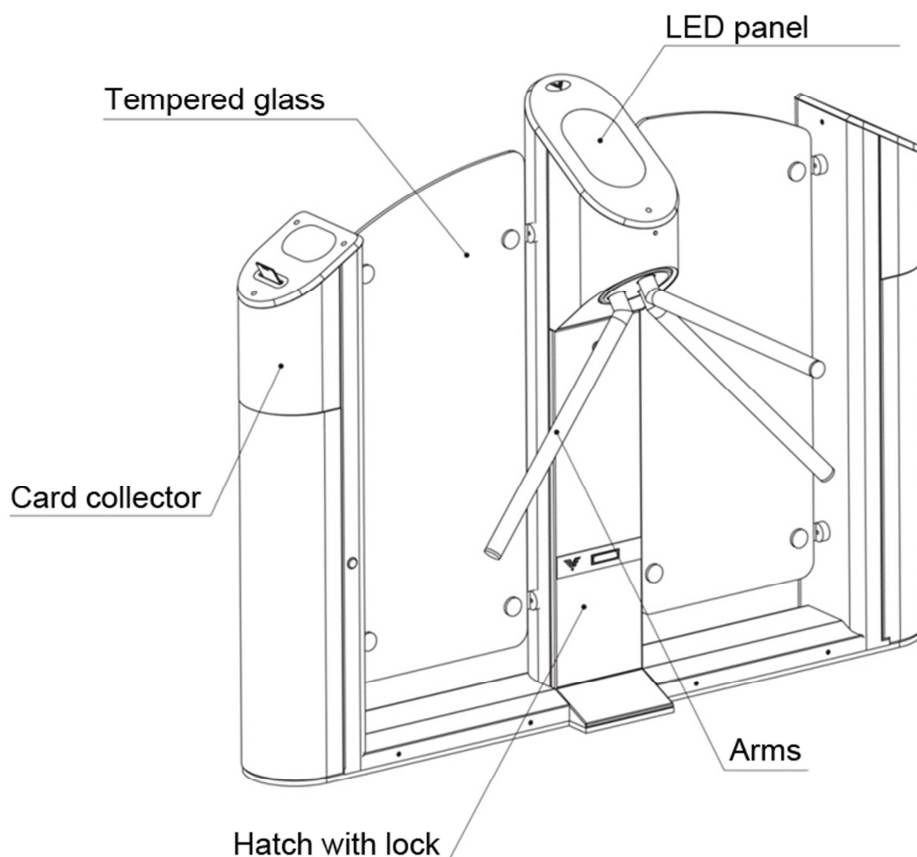

Fig. 1 General view of turnstile

Dimensions of turnstile are shown at Fig. 2

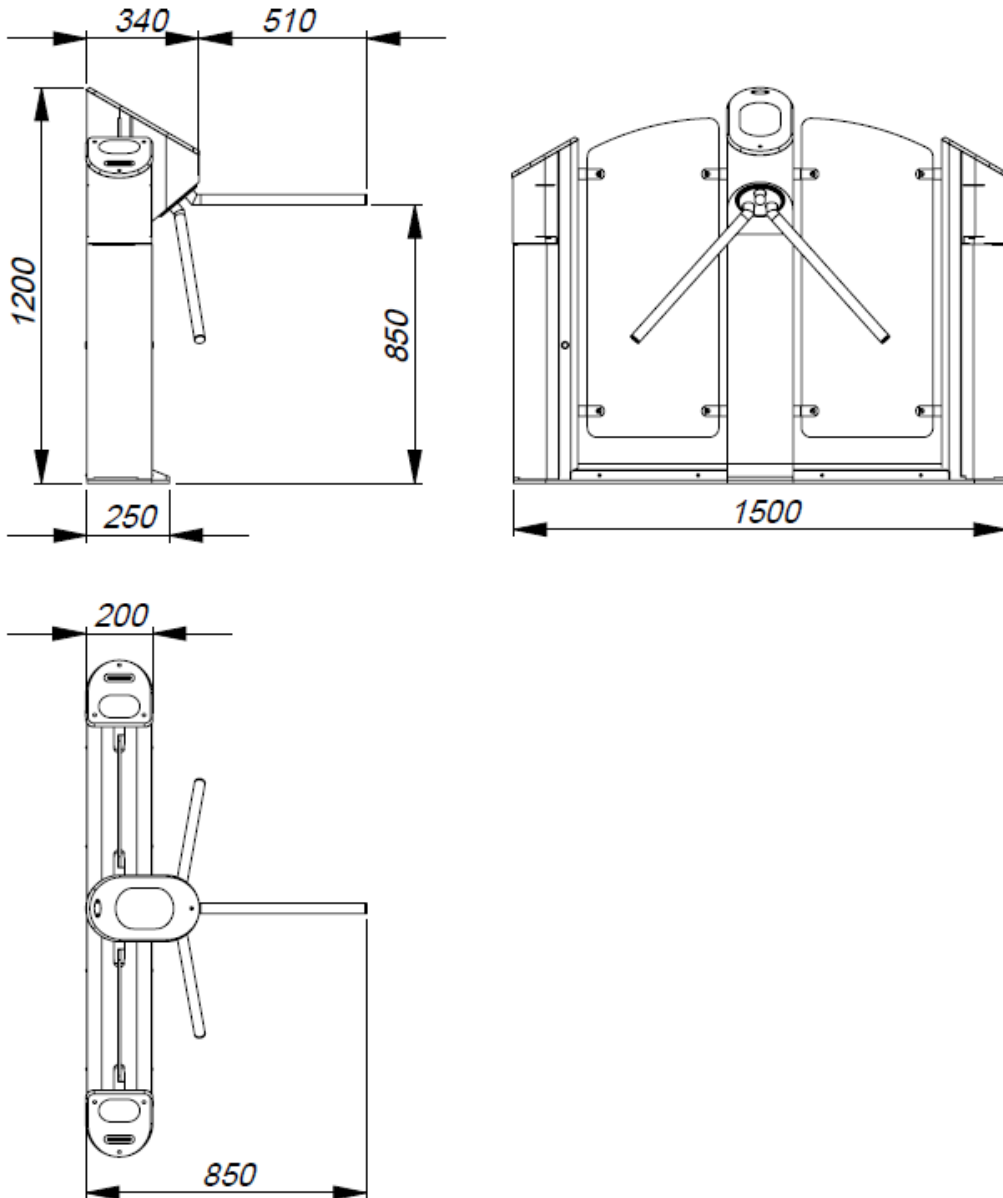

Fig 2. Dimensions of turnstile

Display system

Display system of turnstile consists of three LED panels. The panels are made of artificial stone with insertions made of acrylic glass. Turnstile operating modes are displayed on the panel in the form of mnemonic signs depicting authorization and non-authorization of passage (Fig. 3 and Fig. 4).

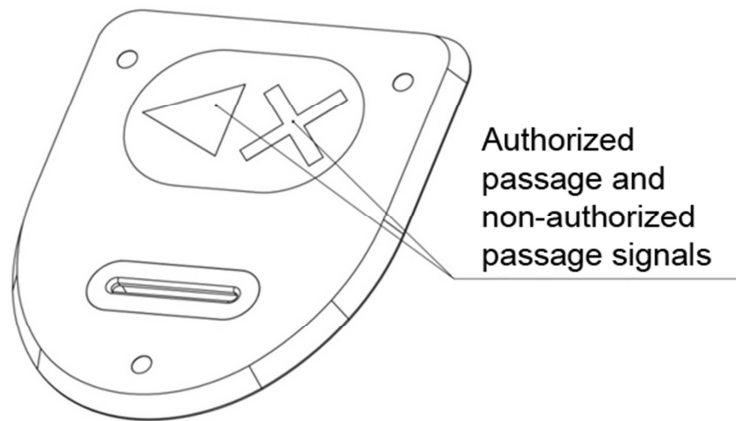

Fig. 3 General view of LED panel

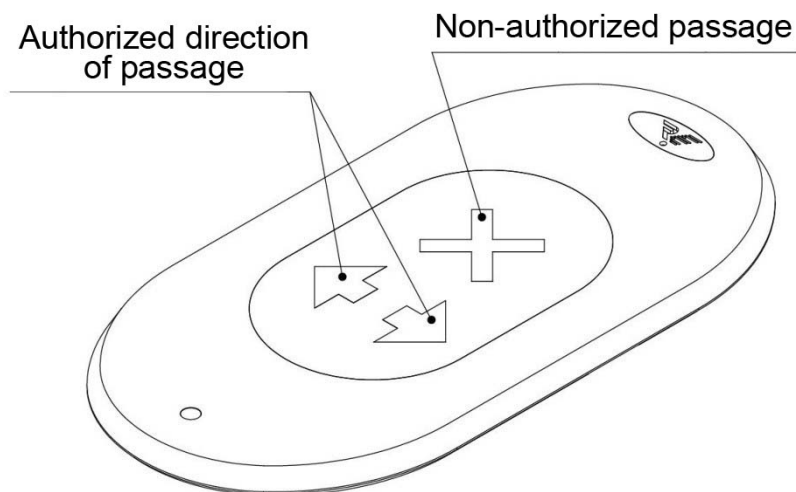

Fig. 4 General view of display panel

Remote Control Panel

The housing of RC is made of polished stainless steel. On the front side there are control buttons and LED indicators of RC operational modes (Fig. 5). The standard supplied cable is 5 meters long.

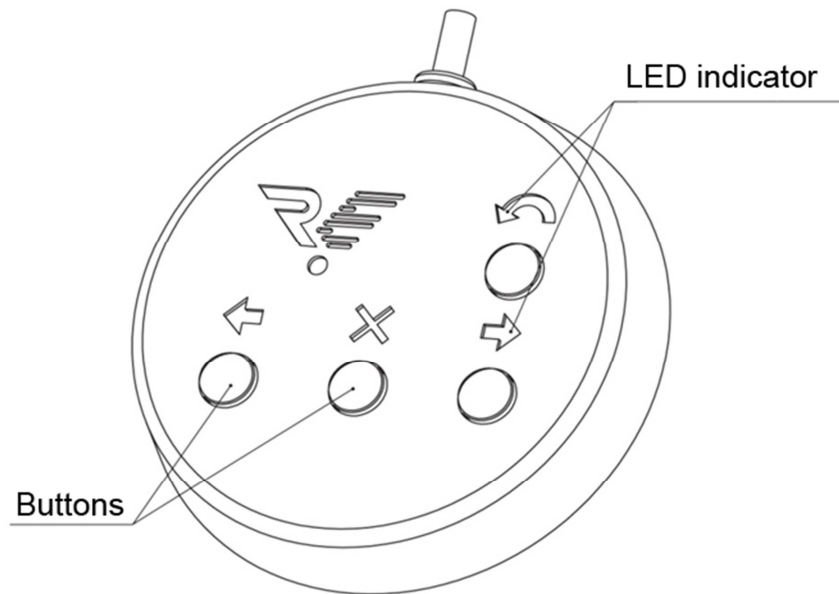

Fig. 5 General view of remote control panel

3. Safety requirements

CAUTION! Failure to comply with the safety requirements specified in this section may result in damage to human life and health, total or partial loss of workability of products and (or) auxiliary equipment.

CAUTION! The producer disclaims any liability for damage to human life and health, total or partial loss of workability of products and (or) auxiliary equipment for non-compliance of the safety requirements specified in this section, as well as terminate the product warranty.

IT IS NOT ALLOWED TO:

- Set the power supply inside the turnstile housing as this could lead to electric shock to persons;
- Set the turnstile other than dry and heated places;
- Impede or accelerate the turnstile arms during on/off “antipanic” mode;
- Apply chemically aggressive cleaning detergents as pastes and liquids.

4. Installation of turnstile

CAUTION: The turnstile should be installed securely to avoid swinging and (or) overthrow during operation. In case of installation on the low strength floors - take action to strengthen the floor at the installation site. Before checking operability of the turnstile carefully read this section of the Guidelines

4.1. Required equipment

Tools used for turnstile mounting:

- electric perforator;
- 20mm diameter carbide drill for drilling holes in the floor for anchors (recommended anchor - SORMAT PFG LB 12-50);
- S10 wrench for hexagon socket head screws;

- slotted screwdriver;
- plumb line or level;
- steel liner for turnstile alignment
- round file
- side cutters

4.2. Installation of turnstile

CAUTION: When designing the mounting site of the turnstile take into account that rotation direction of arms will be counter-clockwise during "antipanic" mode.

4.2.1. Prepare a horizontal surface at the installation site of turnstile.

4.2.2. Prepare cable channel from the site to the installation site of PS, RC, as well as, if required, to the point of ACS and fire alarm connection.

4.2.3. Follow the layout (Fig. 6) prepare and drill 9 holes of 20mm diameter in the floor for anchors. Location of mounting holes according to the outer dimensions of the turnstile is shown in Appendix 3. Depth

of the hole should exceed the length of the anchor for more than 5mm. Put anchors in the holes.

4.2.4. Cable routing is carried out through a hole 1 (Fig. 6) in the lower plate of turnstile. Cable conduit shall be prepared.

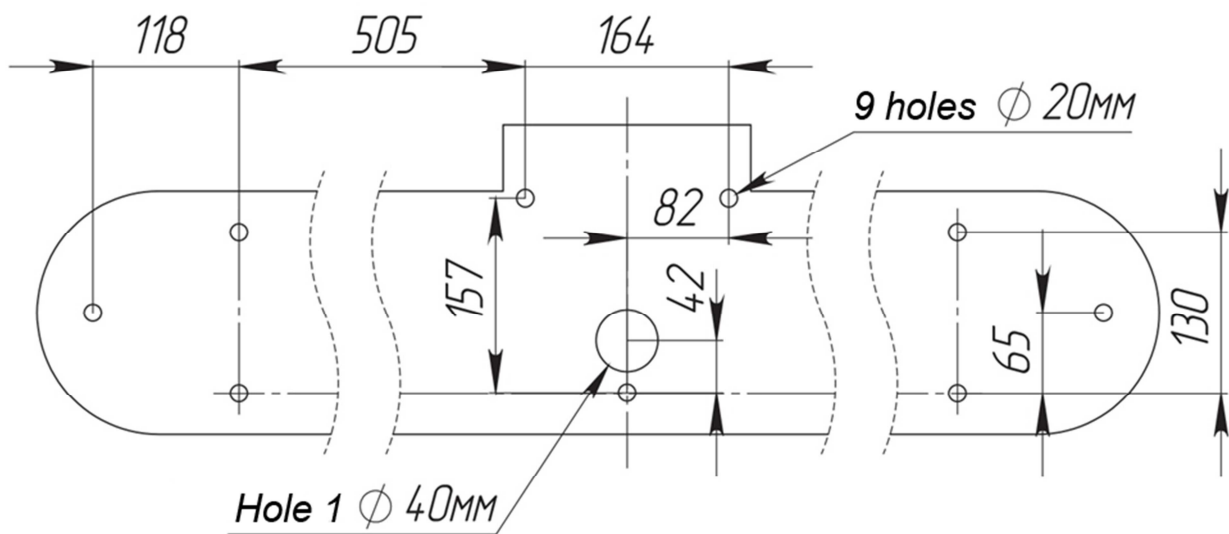

Fig. 6. Installation dimension

4.2.5. Open the box and unpack:

- turnstile;
- remote control panel with cable;
- lock keys (6 pcs.).

4.2.6. Route cable of RC panel, cable of PS unit and, if provided, cables of FA and ACS into cable conduit.

4.2.7. Set the turnstile on a prepared site (Fig. 6). Open the lock and remove the hatch (1, Fig. 7). Undo M6 screw (2, Fig. 8) and remove the base cover of the central stand (3, Fig. 8)

4.2.8. In order to route cables into the side stand with card collector, undo four self-tapping screws (5, Fig. 7), and lift the base housing (4, Fig. 7). Unblock the lock of card collector housing (6, Fig. 7) and open the hatch (7, Fig. 7).

4.2.9. Route into turnstile housing RC and PC cables and, if necessary, FA and ACS cables. Cable routing shall be performed via hole 1 in the lower plate of turnstile (Fig. 6). Secure cables with cable ties.

4.2.10. Align holes in the lower plate of the turnstile together with anchors in the floor. Check the vertical installation in 2 planes. If necessary, use appropriate steel underlayers for proper installation of the turnstile. Fix the housing of the turnstile with 9 screws M12, tightening them to the corresponding anchors by using a S10 wrench with internal hexagon.

4.2.11. Connect the required cables (see Article 5), secure them with cable ties. Place opened and removed parts of the turnstile back in the initial position.

4.2.12. Remove protective film from the housing of the turnstile.

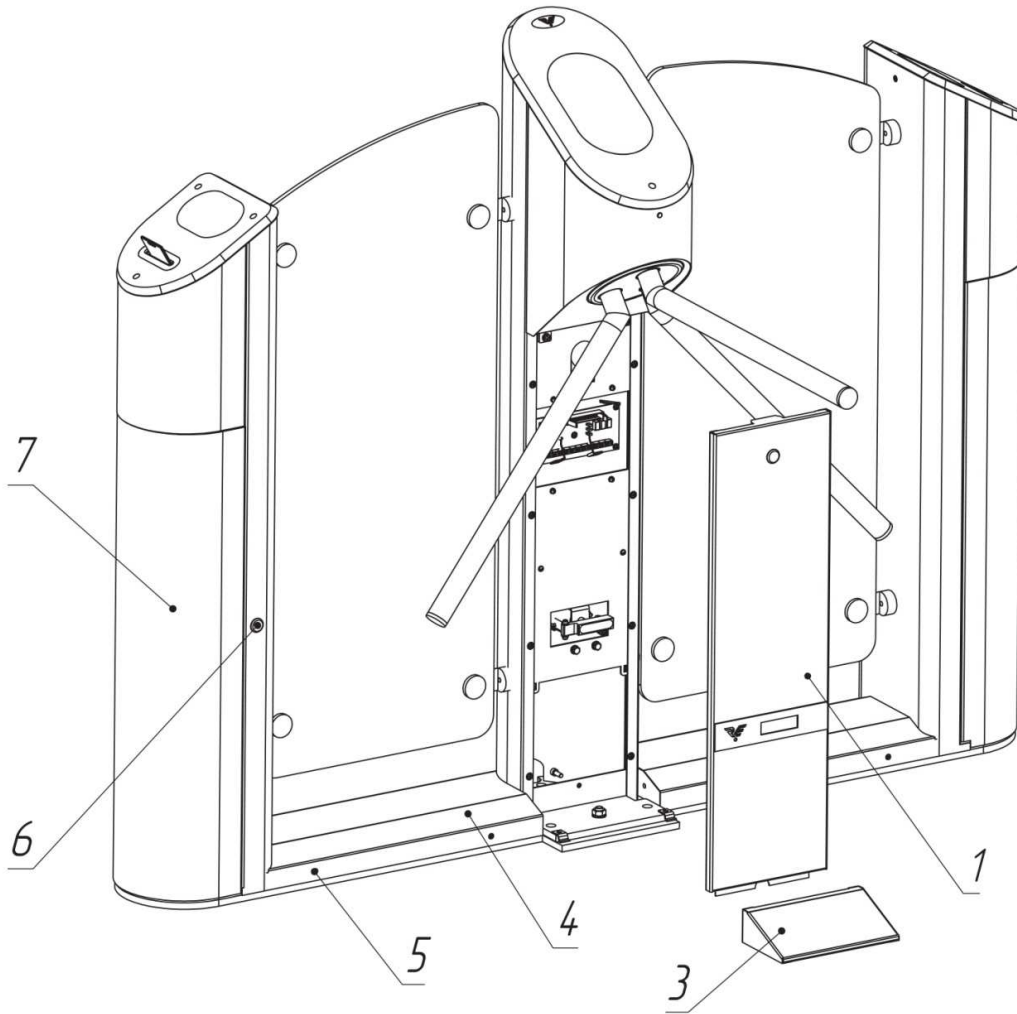

Fig. 7

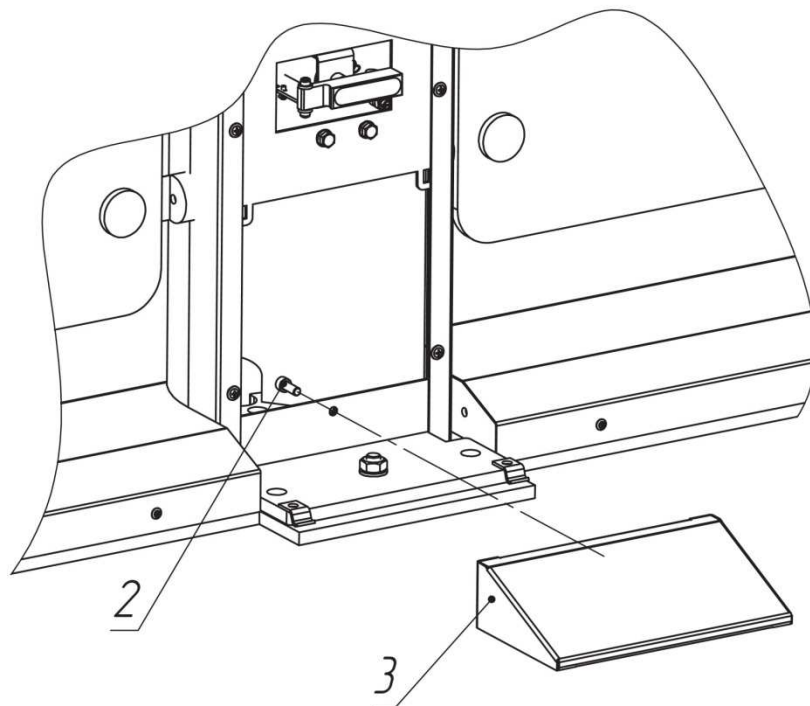

Fig. 8 Installation diagram of turnstile

5. Connecting turnstile

Connection of RC, PS and ACS is performed with the use of motherboard. In order to do it, open turnstile hatch (1, Fig. 7) with a key. Fig. 9 shows the location of motherboard in the housing.

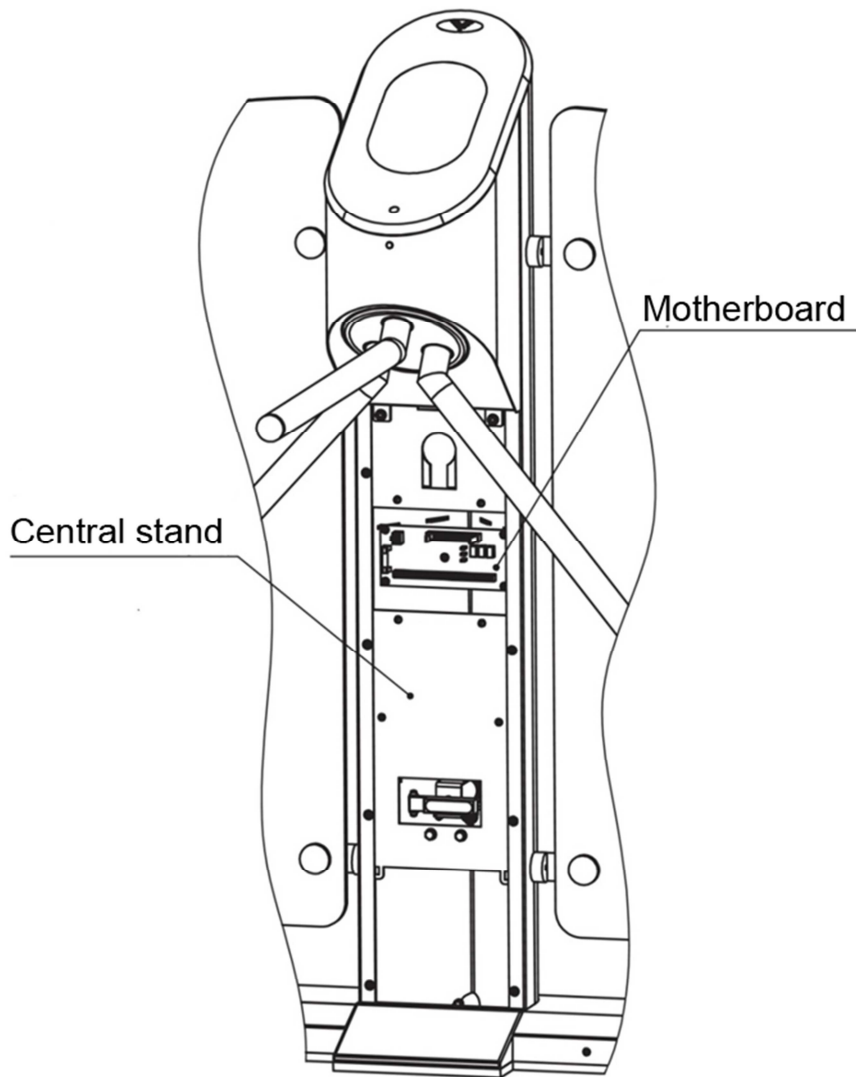

Fig. 9 Location of motherboard

Fig. 11 depicts the motherboard and connectors for PS unit, RC panel, ACS and FA.

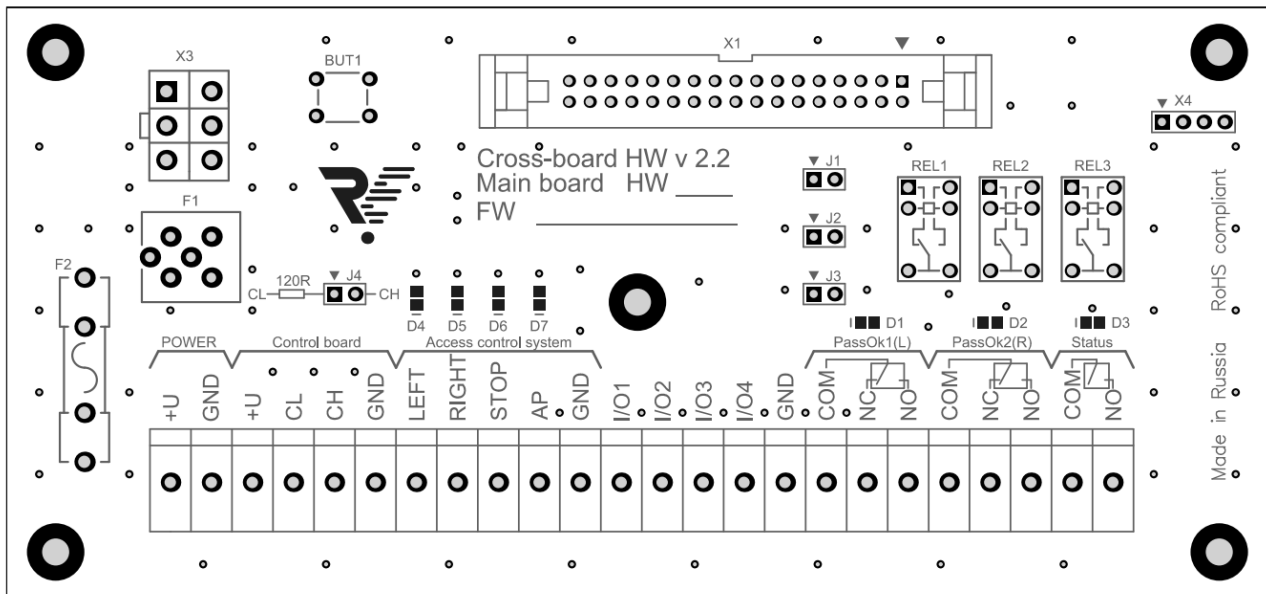

Fig. 11 General view of motherboard

Table 3 Operating modes of turnstile

The position of jumpers	Operating mode of turnstile
J1 removed	Pulse mode (see p .5.3.)
J1 installed	Potential mode (see p 5.3).
J2 installed	Turnstile does not respond to the remote commands. Status of the buttons is transmitted to the outputs I / O1 ... I / O4 (see 5.4)
J2 removed	Turnstile is controlled by remote control. Status of the buttons is transmitted to the outputs I / O1 ... I / O4 (see. 5.4)

- Jumper J3 is not used
- Jumper J4 is used to establish the normal operation of CAN2.0 bus. See Appendix 1.

5.1. Connecting power supply

CAUTION! Do not use power supplies with an output current less than 5A.

Do not install the power supply at a distance more than 25 meters from the turnstile.

CAUTION! Do not use power cable with cross-section less than 1.5 mm² for connection. When the length of the power cable is more than 10 m it is recommended to use a cable with 2.5 mm² cross-section.

Turnstile is powered by 12V DC voltage. Maximum consumption (5A) is observed during "antipanic" mode when arms are folding. PS unit shall be selected on the basis of these parameters. Also note that an increase in the length of the supplied cable increases the voltage drop.

Install the PS unit in a place with easy access for operator. Connect the power supply to the POWER contact set on the motherboard. Connect (+) and (-) contacts of PS unit to (12V) and (GND) terminals respectively.

Make sure the cables are securely connected.

5.2. Connecting remote control panel

RC panel is connected to a Control Board contact set on motherboard. Marking of contacts: 12V, CL, CH, GND.

Connection is made according to contact marking shown in Table 3.

Table 4 Marking of RC contacts

Contacts marking	Wire color
12V	Red
CL	Yellow
CH	Green
GND	Blue

5.3. Connecting access control system (optional)

ACS controller is connected to AccessControlSystem contact set on motherboard. Marking of contacts: LEFT, RIGHT, STOP, AP, GND. Contact assignment is shown in Table 4.

Table 5. ACS contacts assignment

Contacts marking	Contacts assignment
LEFT, RIGHT	single pass left / right (lowest priority)
STOP	non-authorized pass (mode "Stop") (medium priority)
AP	arms folding ("antipanic") (highest priority)
GND	common contact

Inputs for connecting of ACS differ on priorities:

AP input has the highest priority. As long as this input is closed GND contact, arms of the turnstile are collapsed and the turnstile does not respond (!!!) to other signals;

STOP input has the medium priority. When the input is closed on GND contact the turnstile switches to "Stop" and does not respond to other effects, except AP.

LEFT and RIGHT inputs have the same low priority and include a single passage in one direction or another. If both inputs are closed, passage is allowed in that direction the input which was closed first. If passage was not performed the turnstile will move to "Stop" mode automatically within 5 seconds.

CAUTION (!) In case of closure of one of STOP (or) AP inputs - commands from the remote cannot be accepted, i.e. ACS has a higher priority.

AP and STOP inputs operate only in a potential mode, i.e. as long as the input is closed on GND contact the turnstile operates in the corresponding mode. After contacts opening - turnstile switches to the "Stop" mode irrespective to the mode of operated that was used before ACS operation.

LEFT and RIGHT inputs can operate both in the potential and in pulse mode (responding upon GND contact closure). Pulse mode is set on default.

In order to switch to a potential mode set J1 jumper (Fig. 7). In this case the mode of left / right passage turns on only during the control signal to LEFT / RIGHT inputs. Mode of free passage can be set by control signals to both inputs simultaneously. Priorities of LEFT and RIGHT inputs at the switch to the pulse mode remain unchanged.

Motherboard contains two relay outputs for ACS operating on the principle of "dry contacts» - Pass Ok1 and Pass Ok2. NO and COMM -

normally open connection, NC and COMM - normally closed connection. Activation of one of the contact sets suggests the passage in the corresponding direction (PassOk1 - right, PassOk2 - left). "Dry contact" closes / opens when arms rotate at an angle of 60 degrees and return to the starting position when passage is completed.

Motherboard contains relay output for ACS operating on the principle of "dry contacts» - Status. NO and COMM - normally open connection, its contacts close when the turnstile switches to "AP" and D3 LED indicator lights up.

Also the motherboard contains the following LED indicators:

D4 indicates a signal to the «LEFT» input.

D5 indicates a signal to the «RIGHT» input.

D6 indicates signal to the «STOP» input.

D7 signals a signal to the «AP» input.

Jumper J4 shall be installed. It is used to connect a 120 Ohm resistor to CAN 2.0 bus to ensure its normal operation. If two remote control panels are used J4 shall not be installed, because 120 Ohm resistors are installed on CL and CH contacts in remote control panels.

5.4. Connecting RC panel to ACS controller

In some cases RC shall be connected directly to the ACS controller as the passages allowed from the remote (without controller) are regarded by the system as a "forced entry".

To use this connection pattern of turnstile J2 jumper shall be set on the motherboards (Fig. 11). When J2 jumper is set the turnstile does not respond to remote control panel commands but only transmits their status to contacts of I / O1 ... I / O4 terminal boards (Fig. 11) which are open collector outputs. Contacts assignment is shown in Table 5. The numbering of the remote control buttons is shown in Fig. 12. The maximum output current for this set of contacts is 150 mA, maximum voltage rating is 24 W.

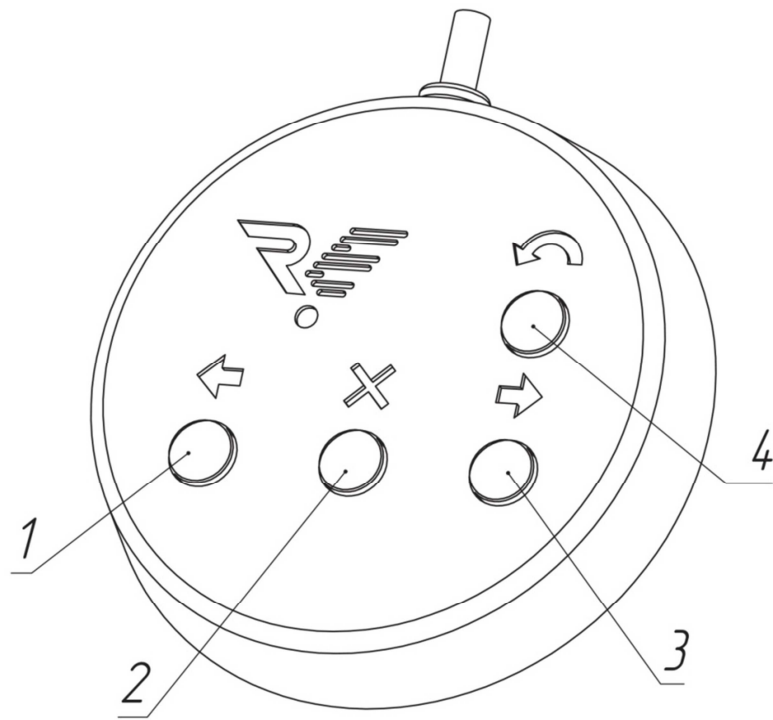

Fig. 12 Numbering of RC panel buttons

Table 6. I/O contact set assignment

Contacts marking	Contact assignment
I/O1	"Left" button status (1,0)
I/O2	"Right" button status (3,010)
I/O3	"Stop" button status (2, Fig.10)
I/O4	"Antipanic" button status (4,0)

I / O1 ... I / O3 outputs show the current state of RC panel buttons, i.e. transistor is opened by pressing the corresponding button. I / O4 output changes its state to the opposite every time the "antipanic" button is pressed.

I / O1 ... I / O4 outputs can be connected both directly to the ACS controller or via relay. When using the relay it is **necessary (!)** to connect diode in parallel with the relay coil (Fig. 13).

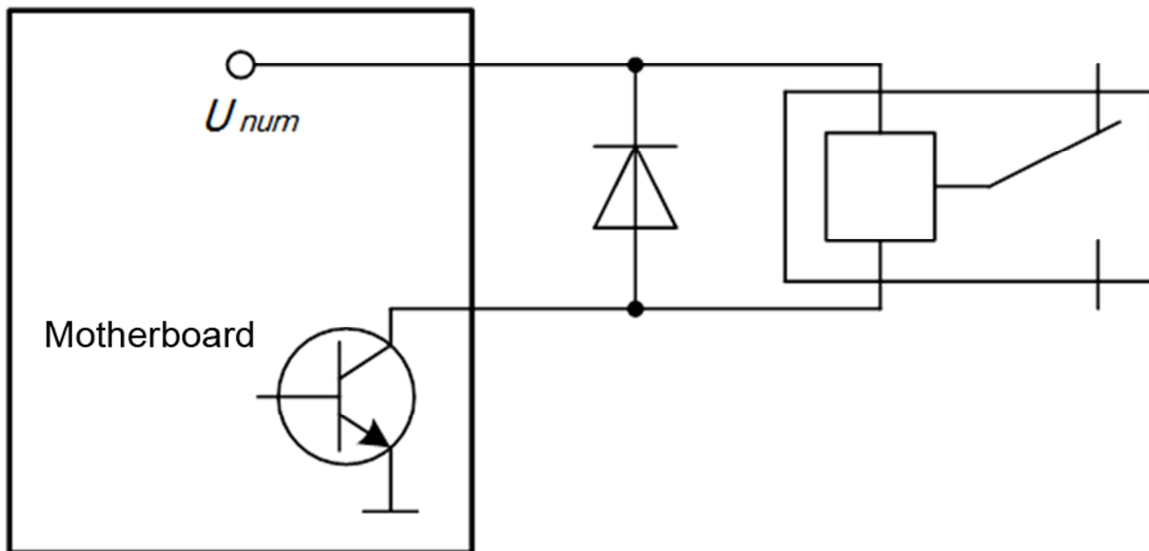

Fig. 13 Connection of diode in parallel with the relay coil

Connection of RC panel to ACS controller is shown in Fig. 14. In this case the controller controls the turnstile via "Left", "Right" and "Stop" contacts,

and the contact "antipanic" is turned on and off with the RC panel. Please note that when the RC panel is connected via ACS controller it is impossible to use turnstile modes which are set by the combination of the RC panel buttons (except for the free passage in the potential control mode. See section 5.3 of Manual). In this case ACS controls these operation modes.

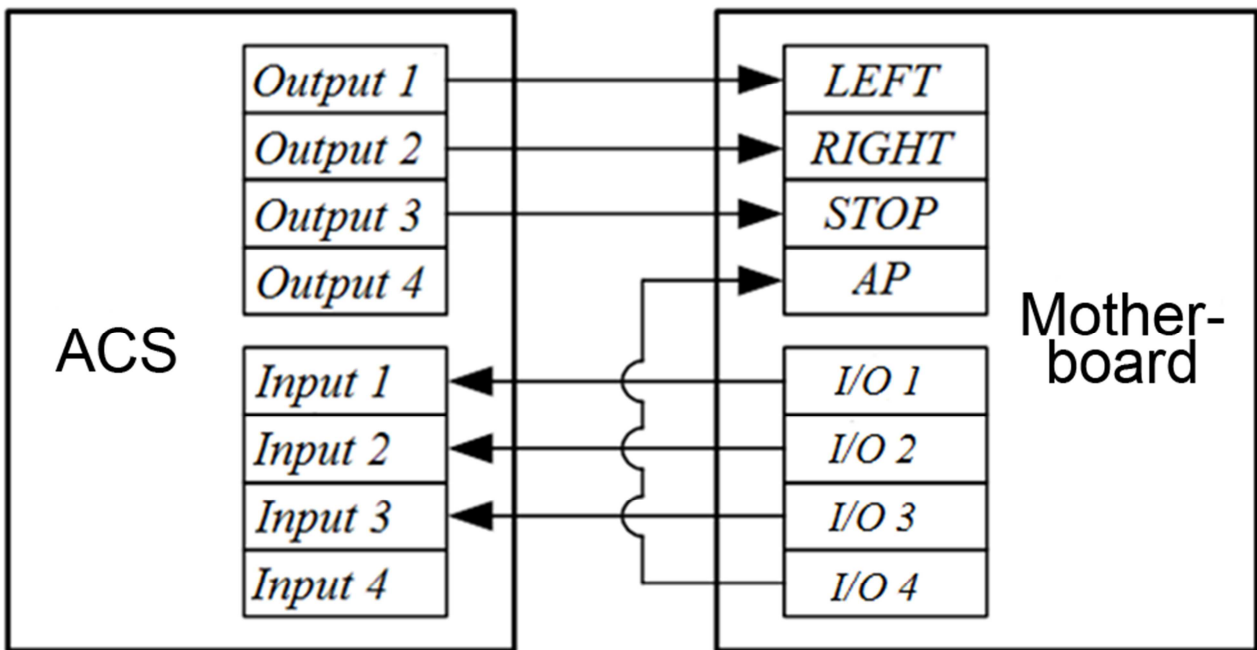

Fig. 14 Connection pattern of RC panel to ACS controller

6. Connecting card collector

6.1. Card collector description

In front of the housing there is a hatch with lock for quick access to collected cards and to the board when PS, OD and ACS cables are connected (fig. 15). The hatch includes a card storage device.

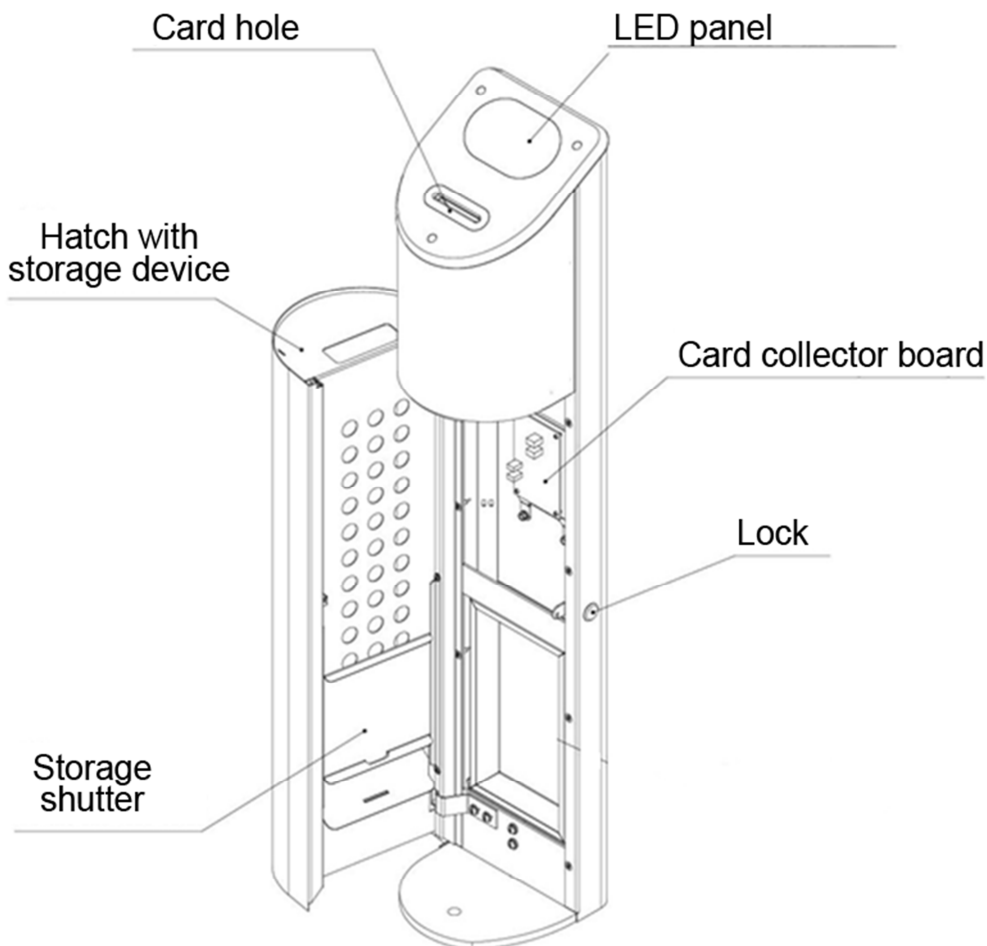

Fig. 15 General view of card collector

ATTENTION (!) Card reader is not included in the delivery set.
Customer can choose reader model suitable for the existing system.

The reader is mounted on a universal adjustable bracket, located under the top cover of the card collector. This solution provides maximum flexibility for installation and connection of the card collector.

Connection of PS, OD and ACS is performed via card collector board. To do this, open the hatch with a key. Figure 15 depicts the location of the board on the card collector stand.

Fig. 16 shows general view of board and connectors for PS, OD and ACS.

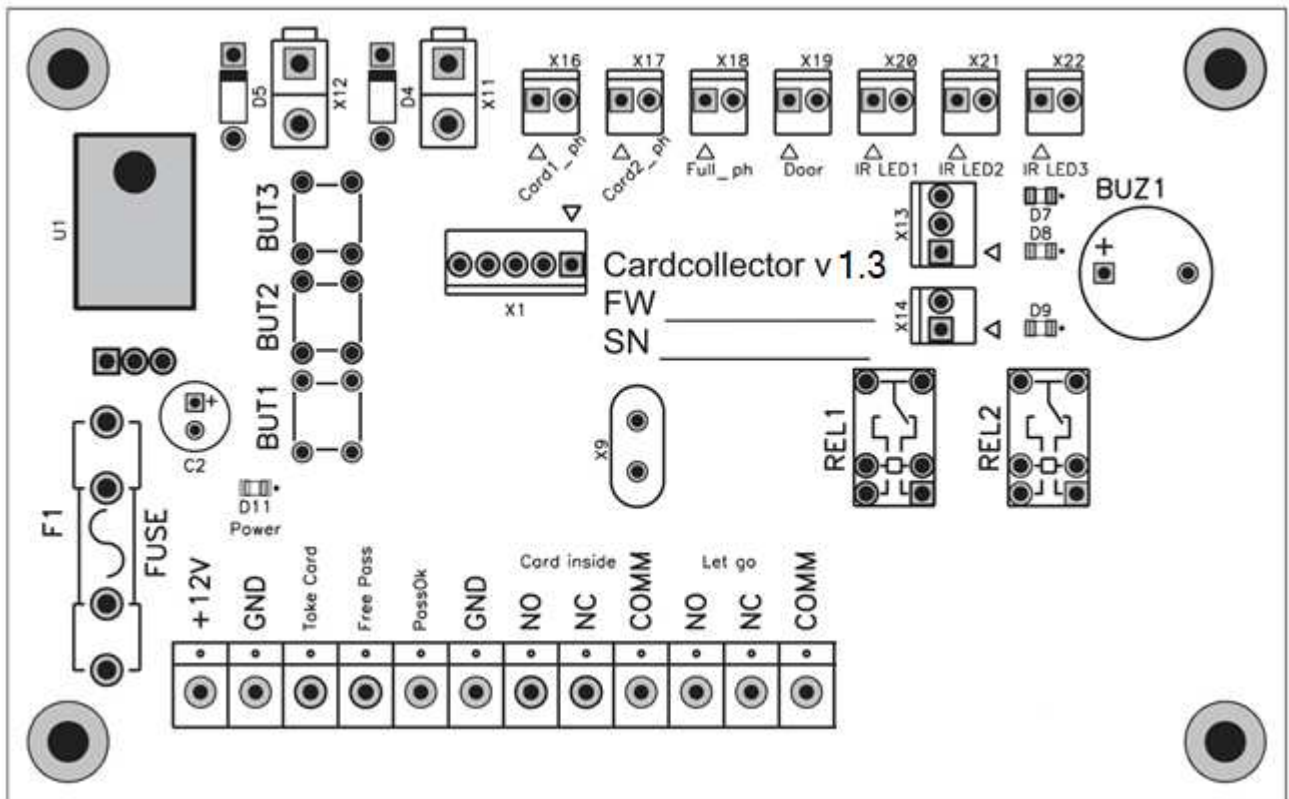

Fig. 16 General view of board

6.2. Connecting power supply

Card collector is powered by a 12 V DC voltage source. Maximum consumption is present in the mode of card collection - 1.5A.

Locate the PS unit to be accessible for operator. Connect PS cable to the card collector board. Connect (+) and (-) contacts of power supply to (+ 12V) and (GND) contacts on the board respectively (Fig. 16). When the card collector board is powered, D11 LED indicator will turn on.

Make sure that cable is connected securely.

6.3. Connecting operating device

Connection of OD to the card collector is performed with the use of two contact sets: "Let Go" and "Pass Ok-GND". Contacts location is shown in Fig. 16.

6.3.1. "Let Go" contact set

NC, NO, and COMM contacts. Relay output operating on a "dry contact" principle, which closes / opens, transmitting passage authorizing signal to OD. NC and COMM - normally closed connection, NO and COMM - normally open connection.

6.3.2. "Pass Ok-GND" contact set

Pass Ok and GND contacts. Pulse input that receives a signal from OD, confirming that the passage was performed. The operating principle is based on normally open contacts. Passage is detected by a contact closure for at least 200 ms.

When authorized card is presented the card collector transmits a signal (see. article 6.3.1) and unlocks the OD for 5 seconds. During this time interval other cards are not accepted. When a signal (a closing between Pass Ok and GND), confirming the passage, is received, the card collector switches into standby mode and can collect the next card. For these reasons, the connection of this contact set is essential to the system capacity.

6.4. Connecting ACS controller

Block diagrams of ACS controller with the use of card collector are shown in Appendix 2.

Connection of ACS controller to the card collector provided by three contact sets: "Take Card-GND" - the signal authorizing collection of guest card, "Free Pass-GND" – the signal authorizing passage and "Card Inside" – the signal confirming card collection. Contacts location is shown in Fig. 10

6.4.1. "Take Card-GND" contact set (signal for collection of guest cards).

Take Card and GND contacts. Pulse input that receives a signal from ACS controller allowing the collection of the card (guest pass). The operating principle is based on normally open contacts. Passage is detected by a contact closure for at least 200 ms.

The signal for collection shall be transmitted no sooner and no later than 2 seconds after putting the card into the card hole of the card collector, otherwise it will be ignored. After receiving the signal within the mentioned time interval card collector opens the shutter and the card is collected. If card collection is confirmed by internal sensors, card collector generates a signal to the OD via "Let Go" contact set (see. article 6.3.1) and to ACS via "Card Inside" contact set. In such case a green arrow indicator on the LED panel turns on.

6.4.2. "Free Pass-GND" contact set (signal for passage authorization).

Free Pass and GND contacts. Input that receives a signal from the ACS controller and allows the passage without card collection (permanent pass). In the case of receiving the signal allowing the passage without card collection, the card reader generates a signal to the OD via "Let Go" contact set (see. Article 6.3.1). In this case a green arrow indicator on the LED panel turns on.

Free Pass input of the card collector shall operate in pulse mode (activation upon contact closure). In pulse mode the voltage is applied to Free Pass input for a short moment and it authorizes the passage. Another passage becomes non-authorized when the passage is performed or after 5 seconds. Pulse mode is set by default, in such case the card collector provides 1 audio signal upon turn-on.

If the card collector provides 2 audio signals, it means that it is set in potential mode.

Potential mode of the turnstile is not provided, the card collector shall be set to pulse mode.

In order to switch into pulse mode:

- Turn off the power
- Wait until LED D11 turns off
- Press and hold BUT1 button on the card collector board
- Turn on the power;
- Press and hold BUT1 button until the card collector provides 1 audio signal, indicating that it is switched to pulse mode of operation;

Set mode is saved when power is turned off. In order to return to the pulse mode repeat the above sequence.

6.4.3. "Card Inside" contact set (signal for card collection confirmation).

NC, NO, and COMM contacts. Relay output operating on a "dry contact" principle which closes / opens for 1 second transmitting a confirmation signal of card collection to the ACS controller. NC and COMM - normally closed connection, NO and COMM - normally open connection.

6.5. Installation of proximity card reader

MatrixIII proximity card reader is used as an example of installation.

Installation of other models of readers may differ

6.5.1. Undo the M4 screw at the rear of the card collector (Fig. 17)

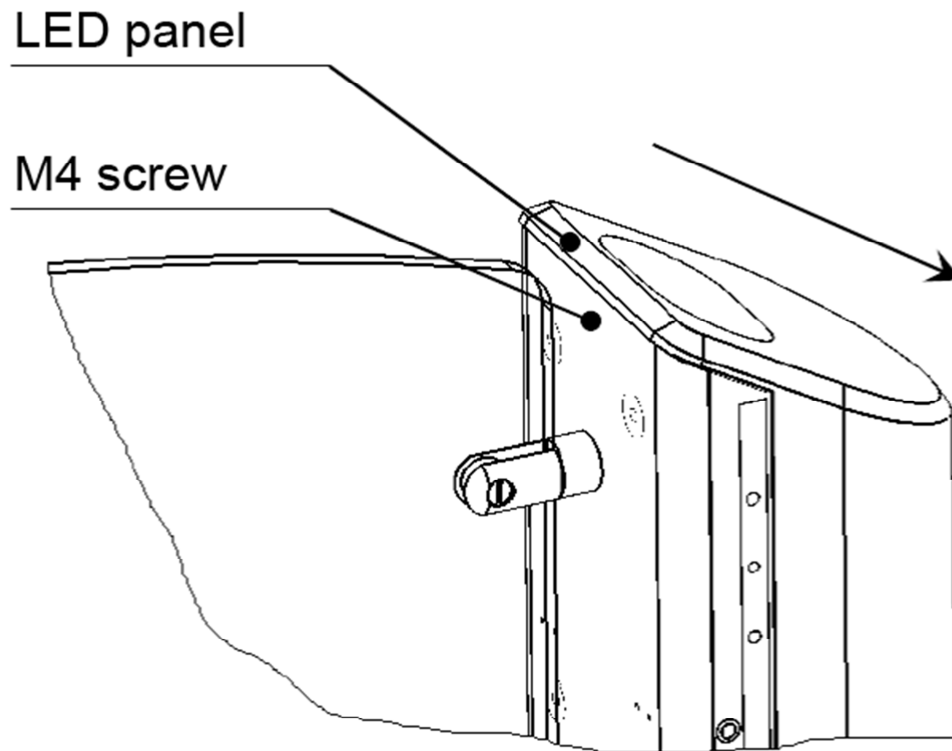

Fig. 17

6.5.2. Slide the LED panel to the stop in the direction indicated in Fig. 17. Carefully lift the panel.

6.5.3. Remove two M4 screws (8, Fig. 18) and remove the universal bracket for readers (2, Fig. 18).

6.5.4. Disassemble the reader, removing the M3 screw (6, Fig. 18), and set its lower part (1, Fig. 18) on the bracket using the two M4 screws with nuts, washers and lockwashers (3, Fig. 18) .

6.5.5. Put the cable (4, Fig. 18) in the bracket hole, install the top cover of the reader (5, Fig. 18). Tighten the M3 screw (6, Fig. 18).

6.5.6. Fix the bracket to clips (7, fig. 18) using the M4 screws (8, Fig. 18). It is recommended to install a reader at an angle of 40 ... 50° to guiding bars for cards (Fig. 19). In this case, the guest and permanent card will be read equally well.

6.5.7. Put the cable of reader in the housing of the card collector.

6.5.8. CAREFULLY (!) set the LED panel in its original position. Tighten the M4 screw and set the decorative cover.

CAUTION! When installing the LED panel in its original position, make sure that wires of optical sensors mounted on the guiding bars for cards will not be damaged by other elements.

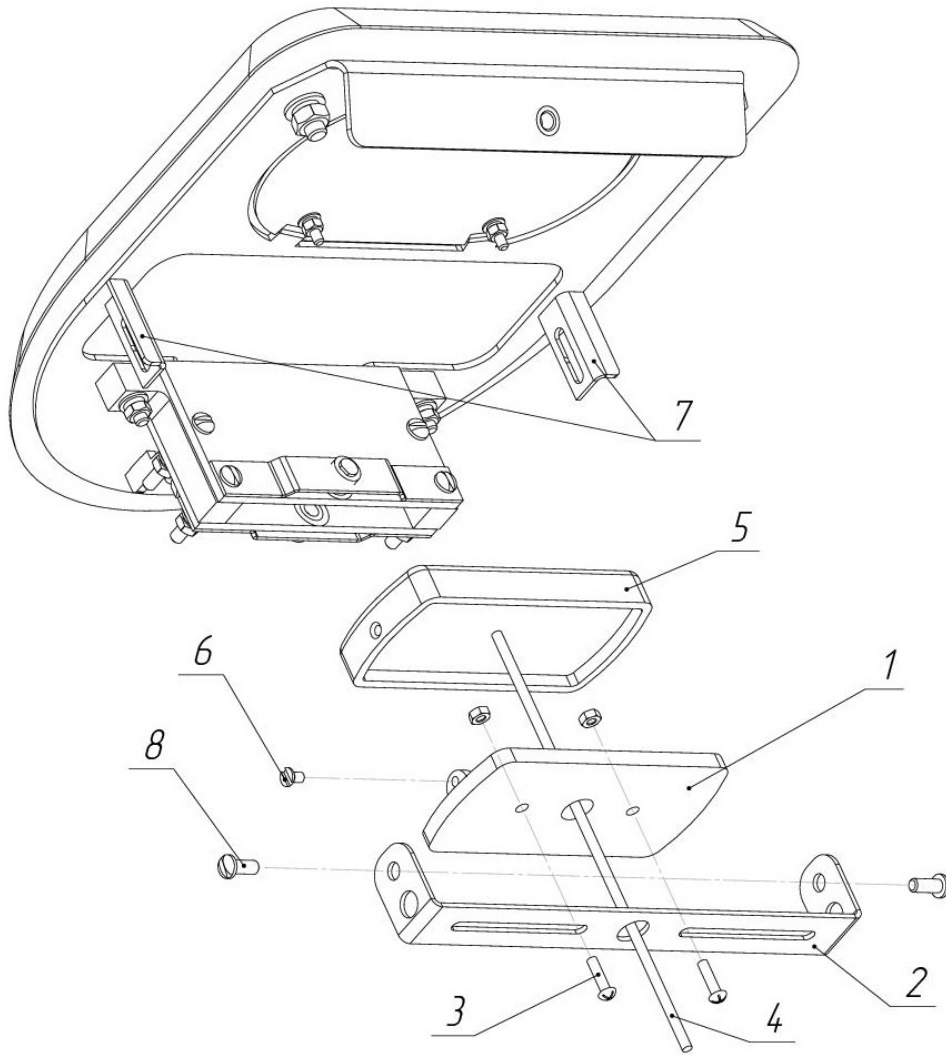

Fig. 18. Installation of proximity card reader

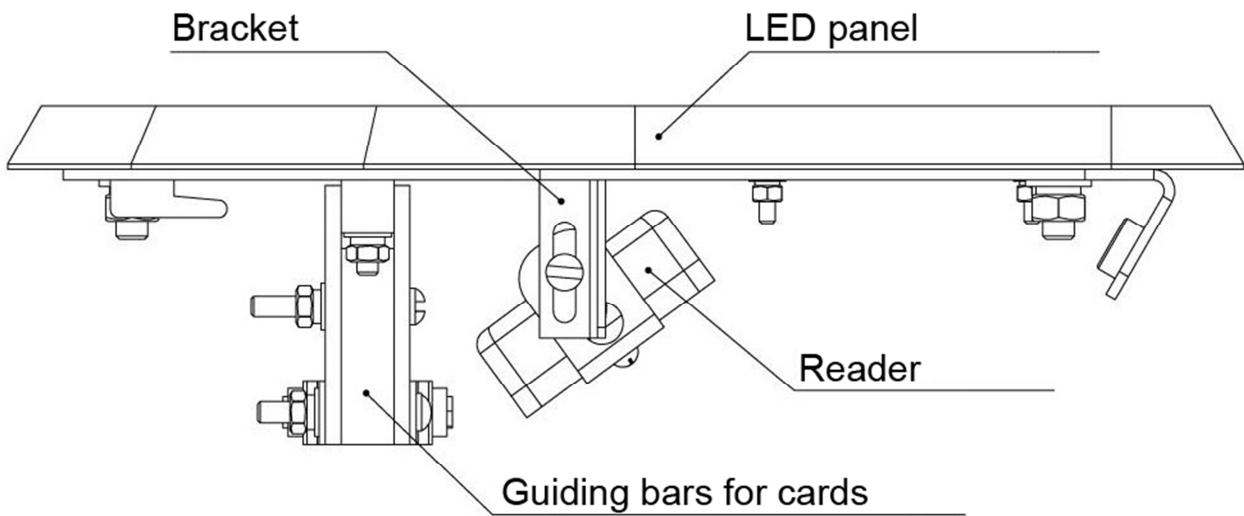

Fig. 19 Recommended option for card reader installation

Appendix 1. Summary of the data bus CAN2.0

The RC panel uses modern CAN2.0 noise-immune bus. According to CAN2.0 standard signal cable length can exceed one kilometer, however correct operation on these distances depends on many factors. Always use Cat5e or Cat6 twisted pair at distances exceeding 25 meters. The total electrical resistance of DC power supply wire shall not exceed 50 ohms. If this requirement cannot be met an additional 12V / 100mA power supply unit (minimum operating voltage of PU - 7.5V). There are 3wires - CL, CH, GND - enough for the correct operation of the turnstile. In this case the power supply wire from the PU to the turnstile is not required. See Fig. 18. Two RC panels can be connected to the same turnstile.

An important feature of the CAN2.0 bus is the use of 120 Ohm resistors at the ends of the bus. The standard RC panel is equipped with such resistor on default. If you use one RC panel it is recommended to connect an additional (second) 120 ohm resistor mounted on the motherboard to CL and CH terminals. It is connected with the use of J4 jumper.

It is not required, however, in case of connection of two RC panels, because required 120 ohm resistors are already installed at the ends of the bus (in RC panels). J4 jumper can be taken off.

A special RC panel is required to operate several turnstiles simultaneously. Standard RC is not appropriate for this purpose.

Appendix 2. Block diagram of ACS using card collector

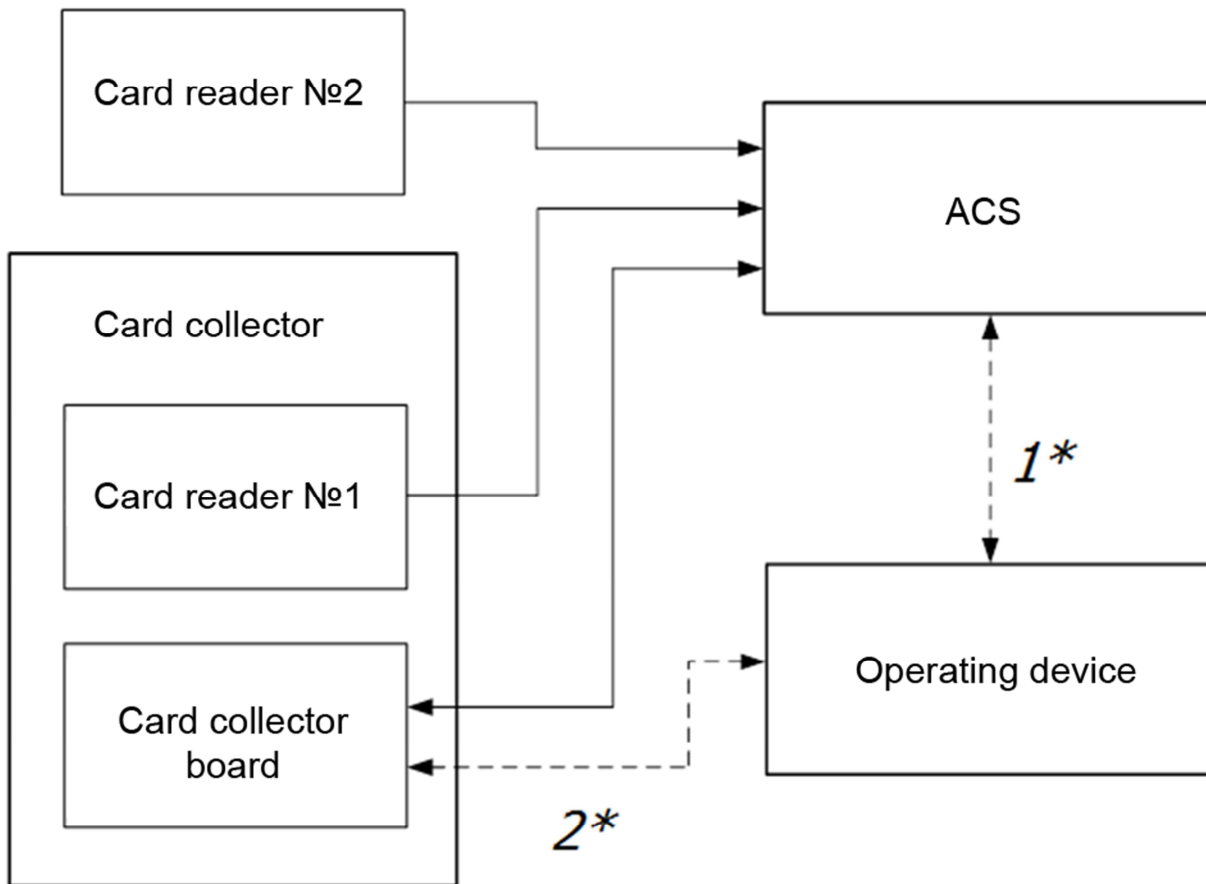

Fig. 20. Block diagram №1

Figure 20 shows the most common connection circuit of card collector. OD can be controlled either by ACS controller or by the card collector directly, that is why connections 1* and 2* are drawn by dotted lines. This scheme features two readers. The second reader shall be installed outside the card collector, which is not always aesthetically and practically acceptable. If installed close to each other, proximity readers can create mutual interference.

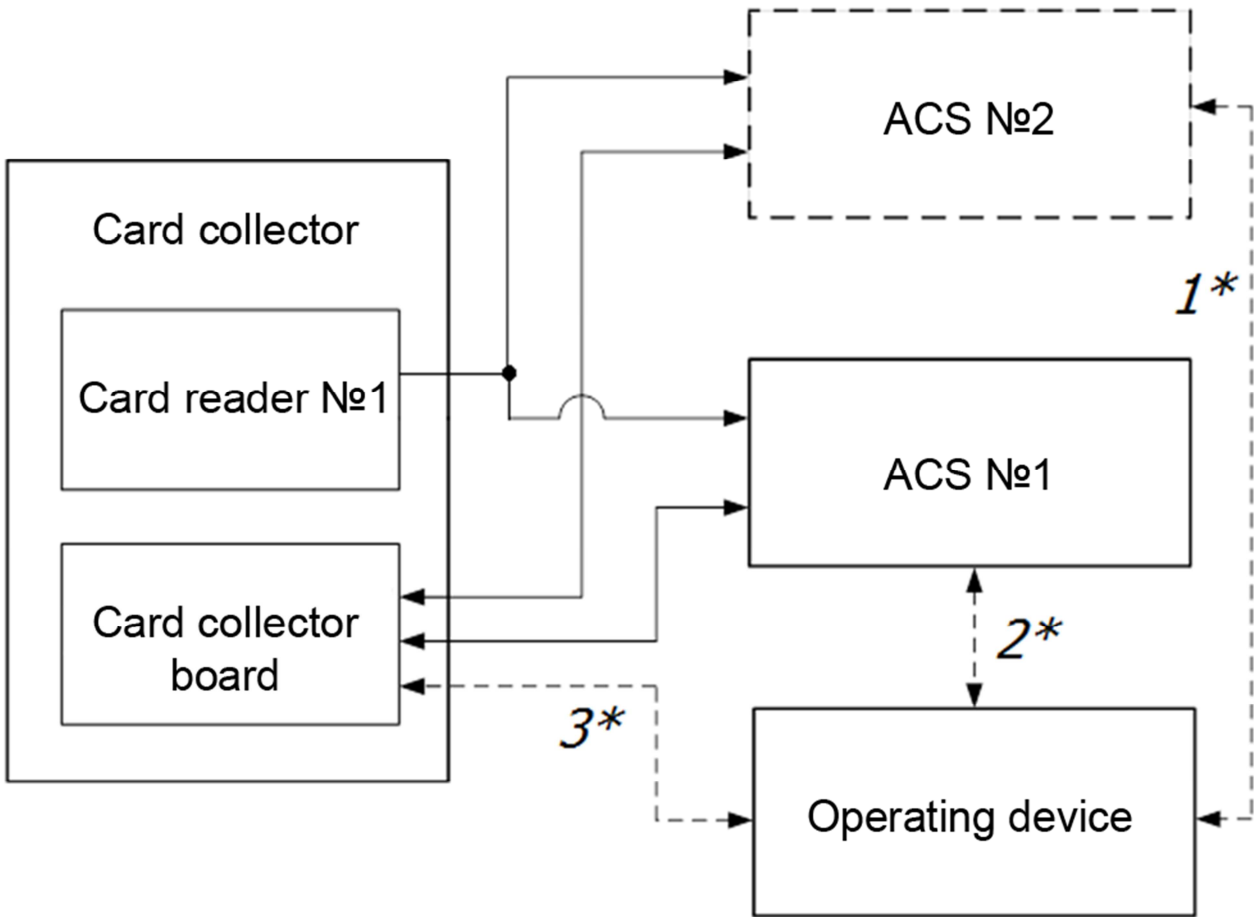

Fig. 21 Block diagram №2

Fig. 21 shows a more advanced but also a more high-cost circuit connection. The advantage of this scheme is that it uses only one reader installed in the card collector. Wiegand interface provides a possibility to connect several identical ACS controllers to one reader in parallel.

ACS controllers are connected to different inputs of the card collector. Memory of one of the controllers contains data on permanent card; memory of the second controller - on guest card. Reader transmits card code to both controllers and the card collector receives a corresponding signal depending on the type of card.

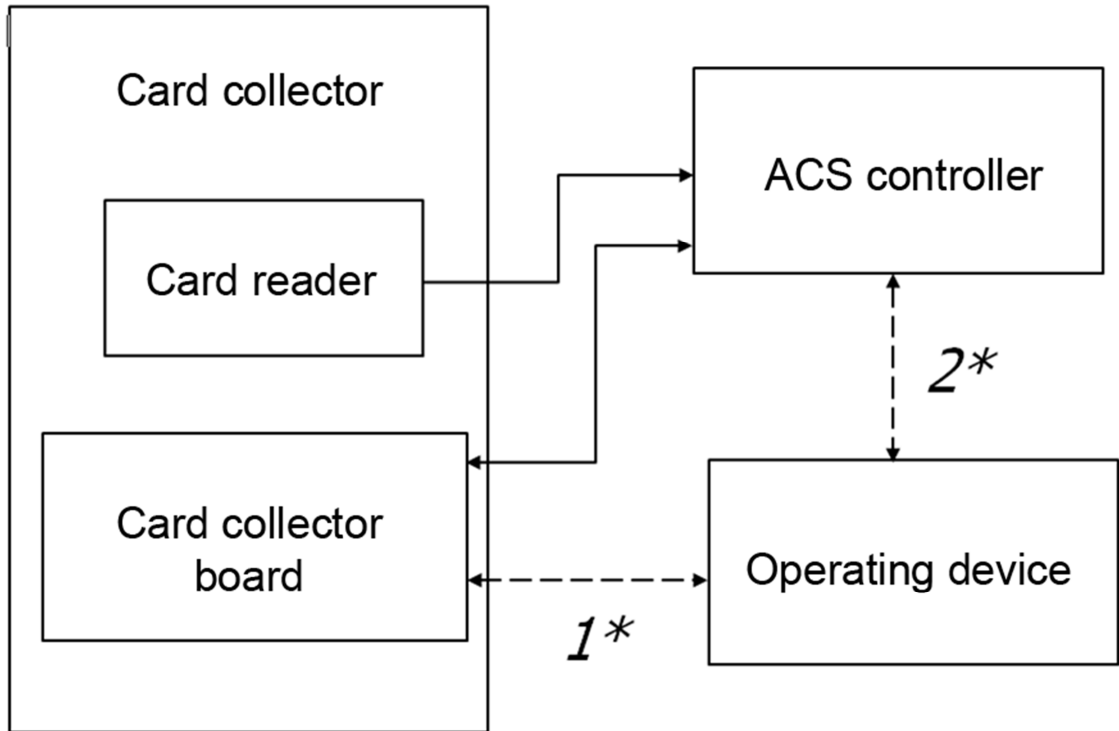

Fig. 22 Block diagram №3

The block diagram #3 (Fig. 22) can be considered to be a logical development of the block diagram #2. It reduces the cost of installed system. For this purpose the controller with two output signals to one input of a reader (i.e., the controller can distinguish the guest cards and permanent cards transmitting a signal to the corresponding output) is used.

Appendix 3. Location of mounting holes in relation to the overall dimensions of the turnstile

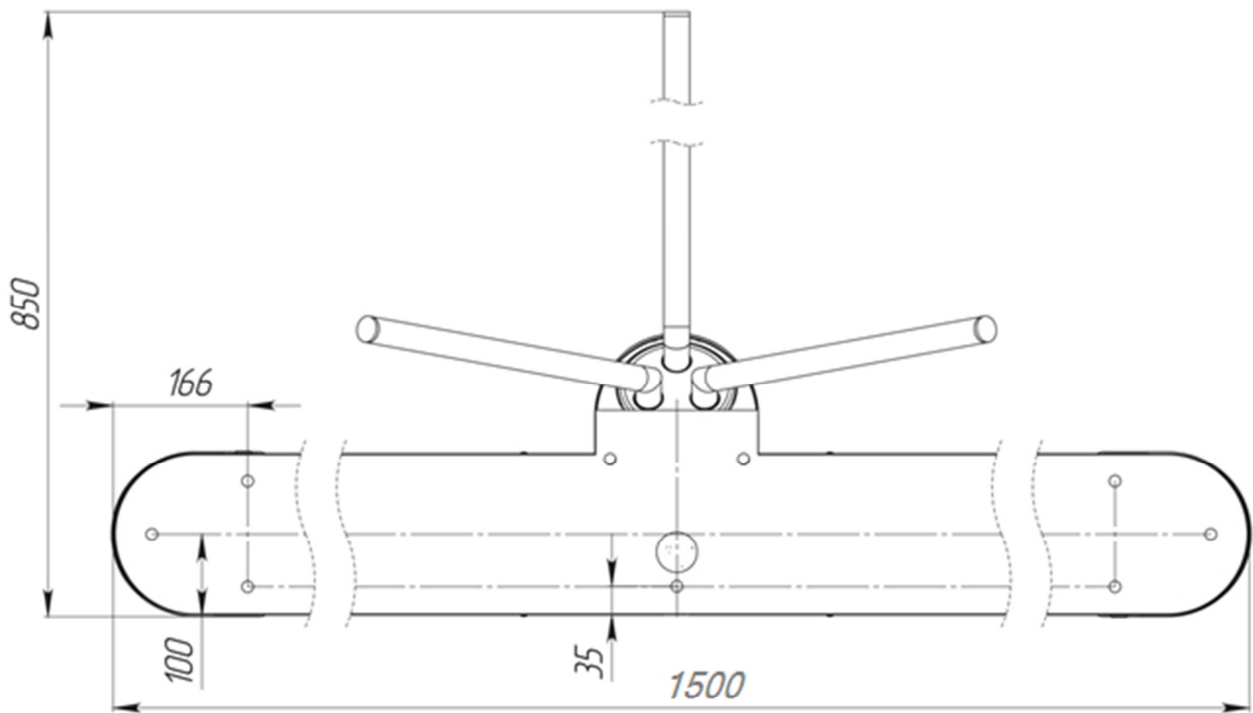

Fig. 23 *Location of mounting holes in relation to the overall dimensions of the turnstile*



ООО "Vozrozhdenie"

192289 Saint Petersburg

Sofiyskaya st., 66

Tel./fax +7 (812) 366 15 94

www.oxgard.com

info@oxgard.com

