

MAINTENANCE  
OPERATIONS

## Praktika T-03(K) turnstile







# Contents

1. General information .....	4
2. Conditions for maintenance .....	5
3. Partial disassemble of the turnstile.....	5
4. Checking turnstile parts.....	13
5. Lubrication of moving parts.....	14
6. Assembling and performance checking of the turnstile .....	17

## **1. General information**

1.1. During operation of the turnstile in order to maintain efficiency and to ensure calculated lifetime the maintenance operation of the turnstile shall be carried out periodically, including the warranty period (hereinafter MO).

1.2. MO shall be performed once in 6 months. Should there be any failure MO should be performed immediately after repair works.

1.3. During MO it is recommended to carry out the work by two qualified mechanical and electrical engineers, acquainted with the manual.

1.4. MO includes the following scope of work: partial disassemble of the turnstile, cleaning of load-bearing frame, checking of parts and units fixation, lubrication of subject to wear parts of actuating device, checking of belt tension, setting the dismantled parts and a general inspection of the turnstile.

## **2. Conditions for maintenance**

CAUTION! It is strictly forbidden to carry out work with powered turnstile. Failure to follow these safety requirements could result in damage to human life and health, total or partial loss of product workability and (or) auxiliary equipment.

CAUTION! Do not remove motherboard located under the display panel. Otherwise the manufacturer will void the product warranty.

CAUTION! It is not recommended to adjust the limitation units of solenoid stroke, Hall sensor bracket and spring tension. These components are adjusted at the factory. Violation of these adjustments may lead to failures of the whole electromechanical system.

## **3. Partial disassemble of the turnstile**

In order to get access to all elements of the turnstile it is necessary to perform a partial disassembly. Scope of work includes the dismantling of the LED panel, the hatch with a lock and the lower panel (Fig. 1).

3.1. Turn off turnstile power supply and disconnect it from the electrical network.

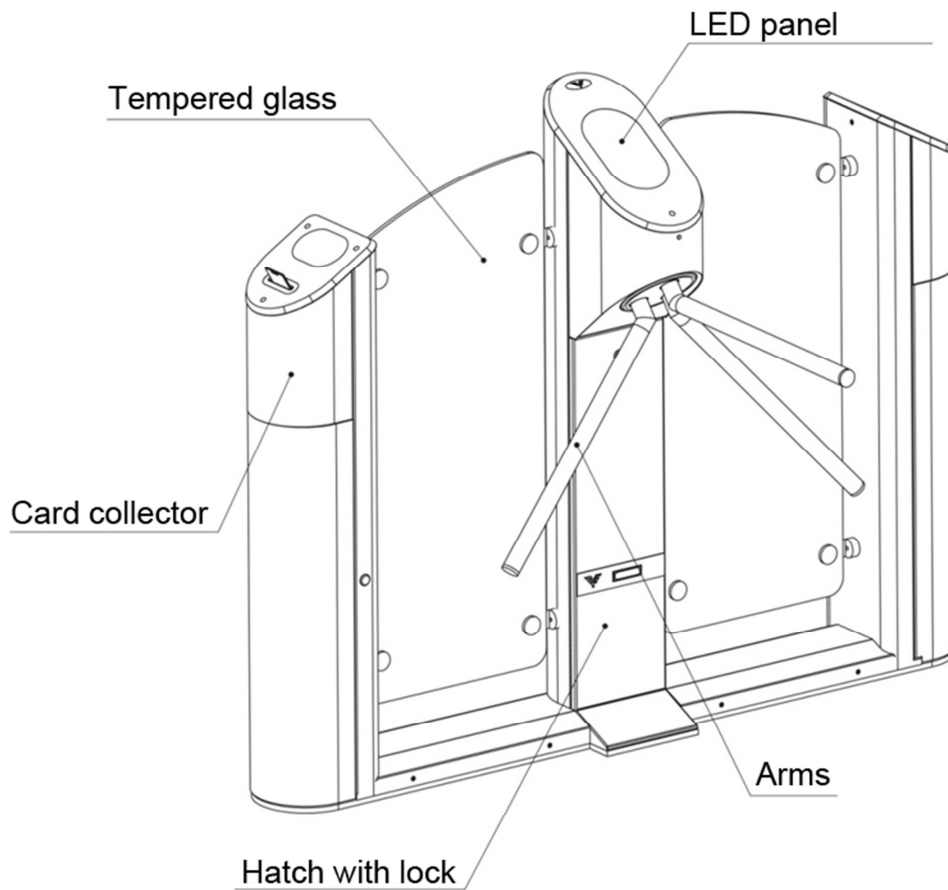
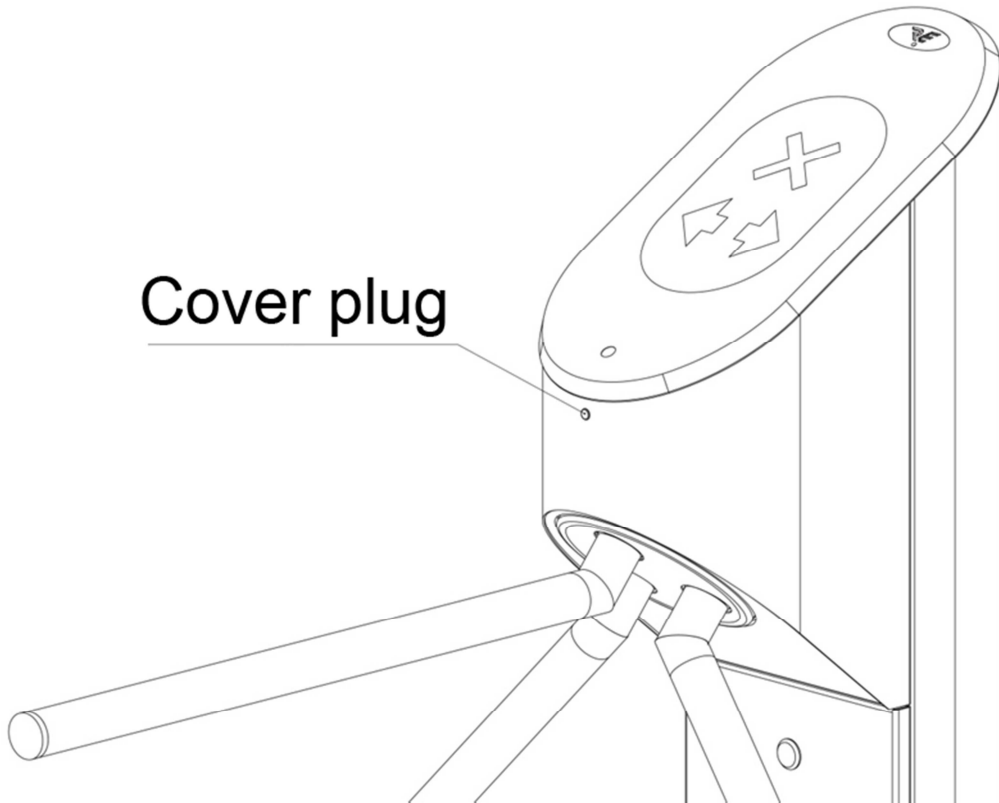


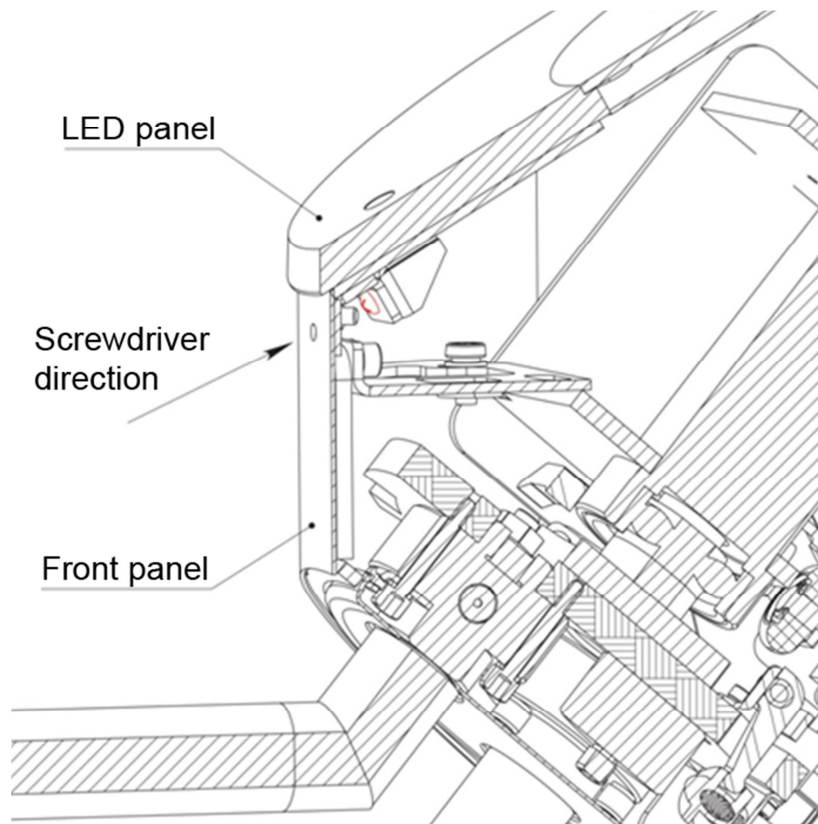
Fig. 1

### 3.2. Removing LED panel:

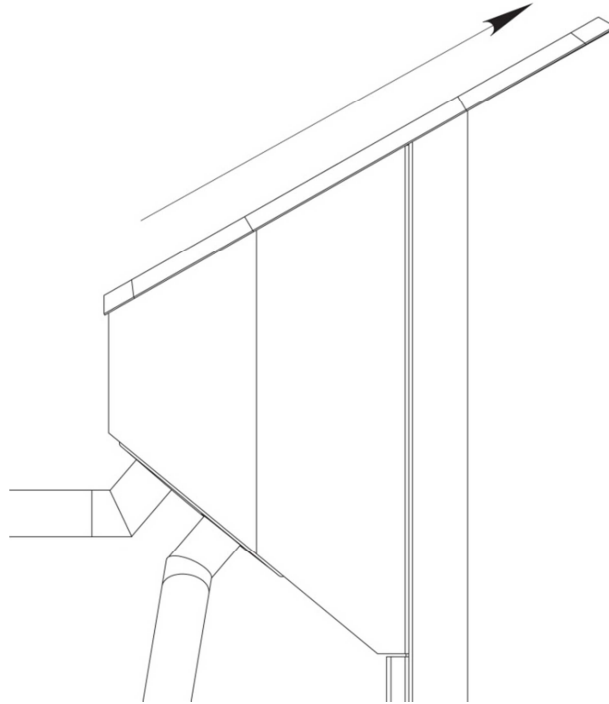
- Remove the plastic cover plug from the hole (Fig. 2);
- remove the screw fixing the LED panel using crosshead screwdriver in the direction shown in Fig. 3;
- slide the LED panel to the direction indicated in Fig. 4, and lift it up;
- Disconnect the cable from the LED panel.



*Fig. 2 Central stand of turnstile*



*Fig. 3*

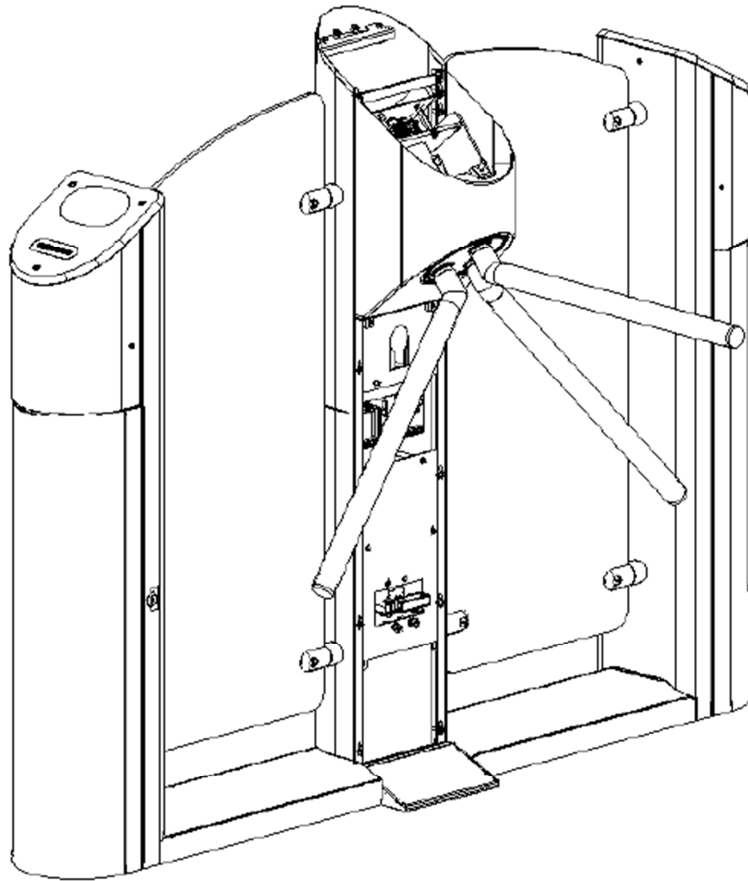


*Fig. 4 Central stand of turnstile*

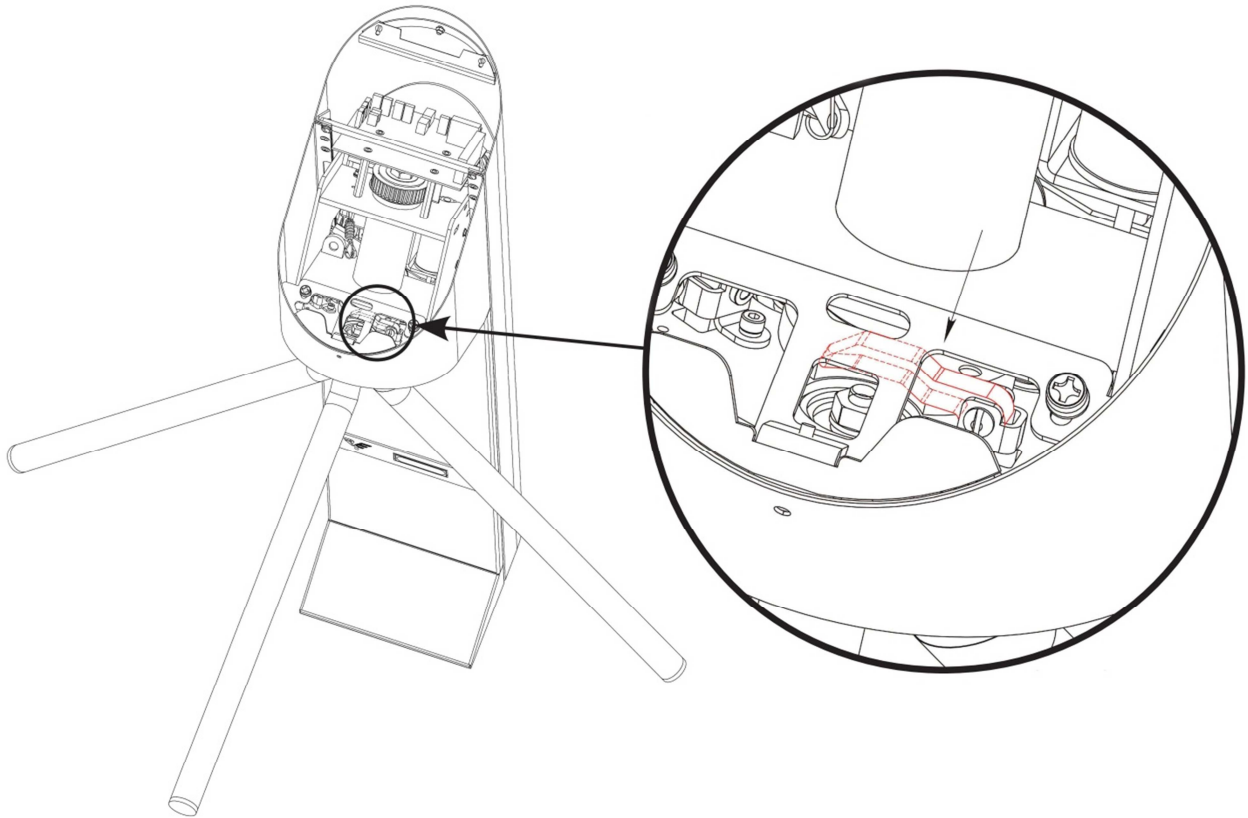
3.3. Unlock the hatch and remove it. The result is shown in Fig. 5.

3.4. Next step is to fold the arms. In order to do it press gently on the arms fixing cam in the direction shown in Fig. 6. Arm shall be rotating freely about the short axis. Fold the second arm in the same manner by turning the disc. The result is shown in Fig. 7.

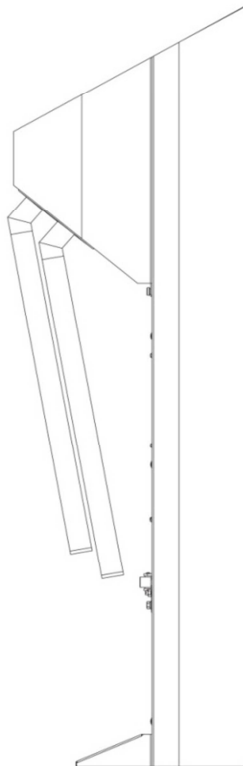




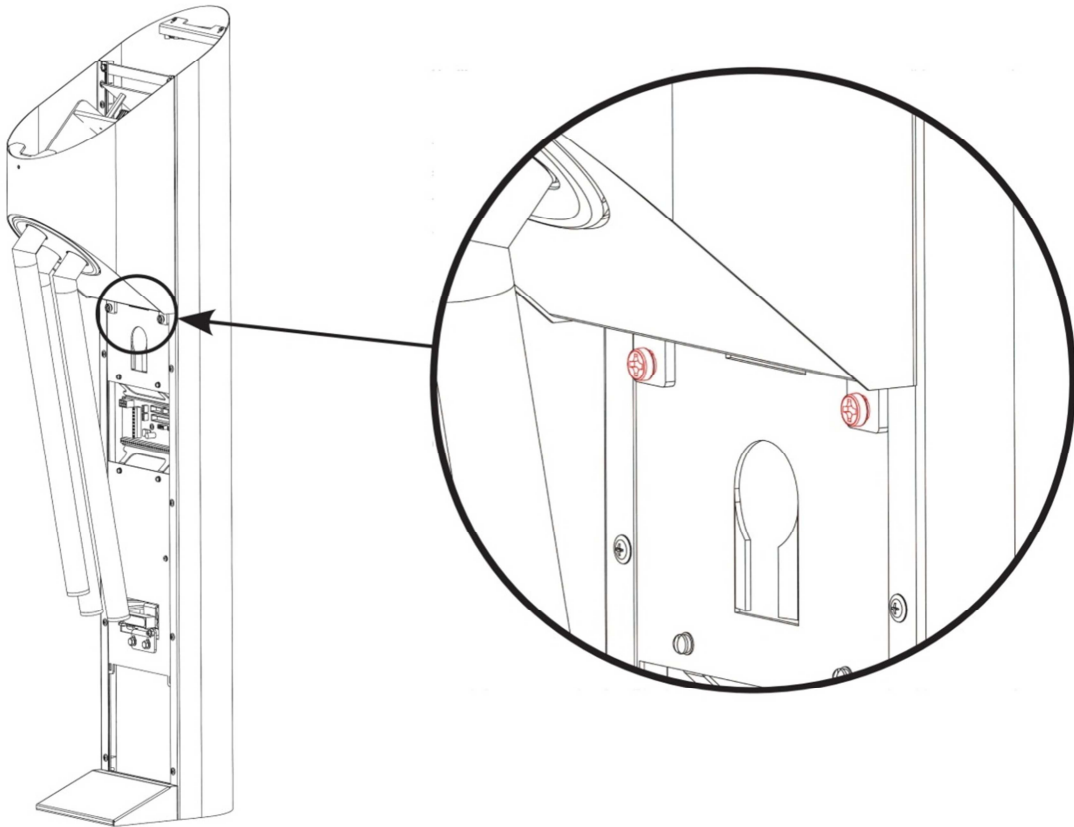
*Fig. 5*



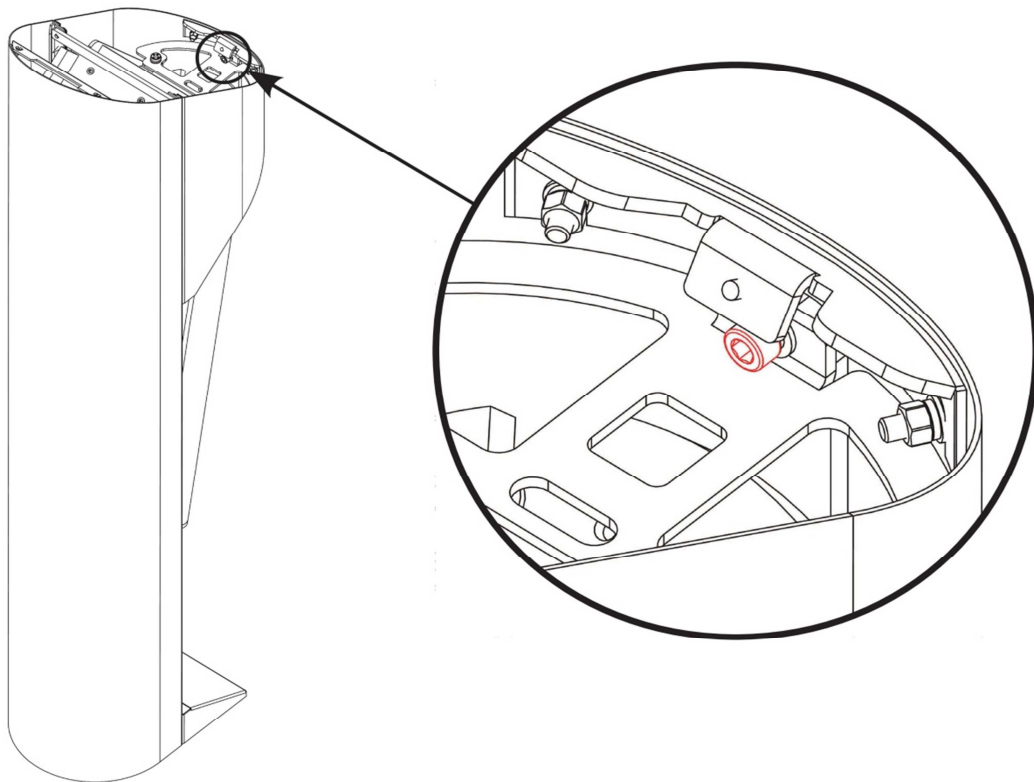
*Fig. 6 Central stand of turnstile*



*Fig. 7 Central stand of turnstile*



*Fig. 8 Central stand of turnstile*

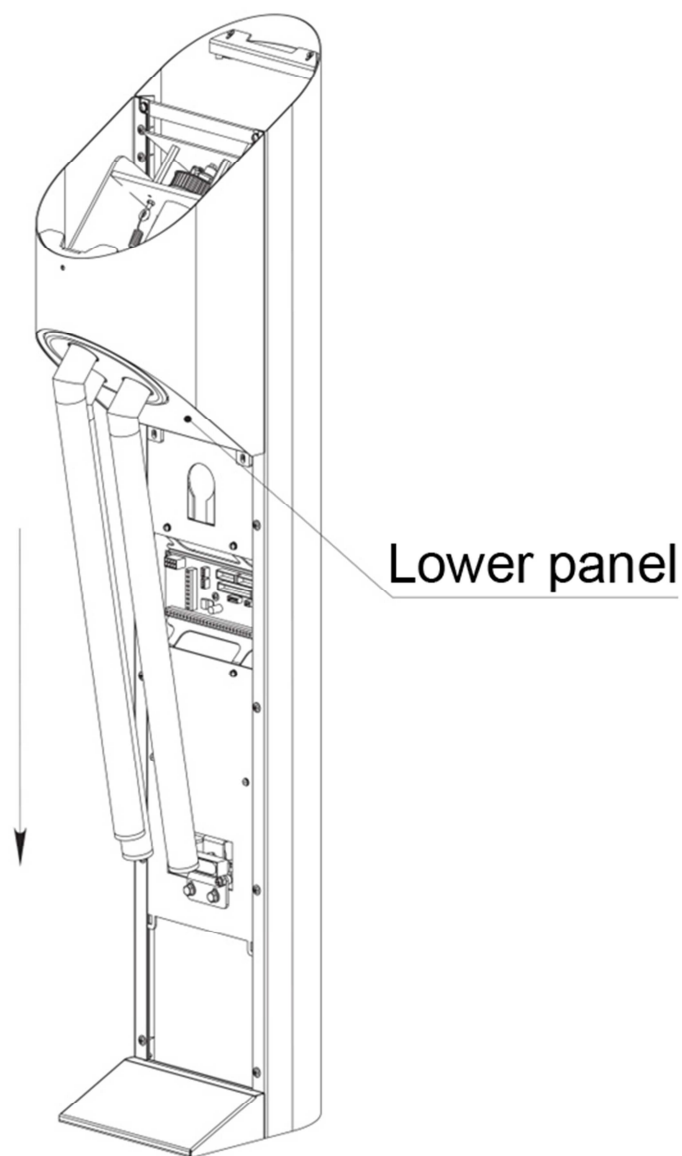


*Fig. 9 Central stand of turnstile*

3.5. Removing of the lower cover of turnstile:

- Remove two M6 DIN7985 screws (Fig. 8);
- Remove M6 GOST11738-84 screw (Fig. 9);
- Remove the lower cover by moving it vertically down, as shown in Fig.

10

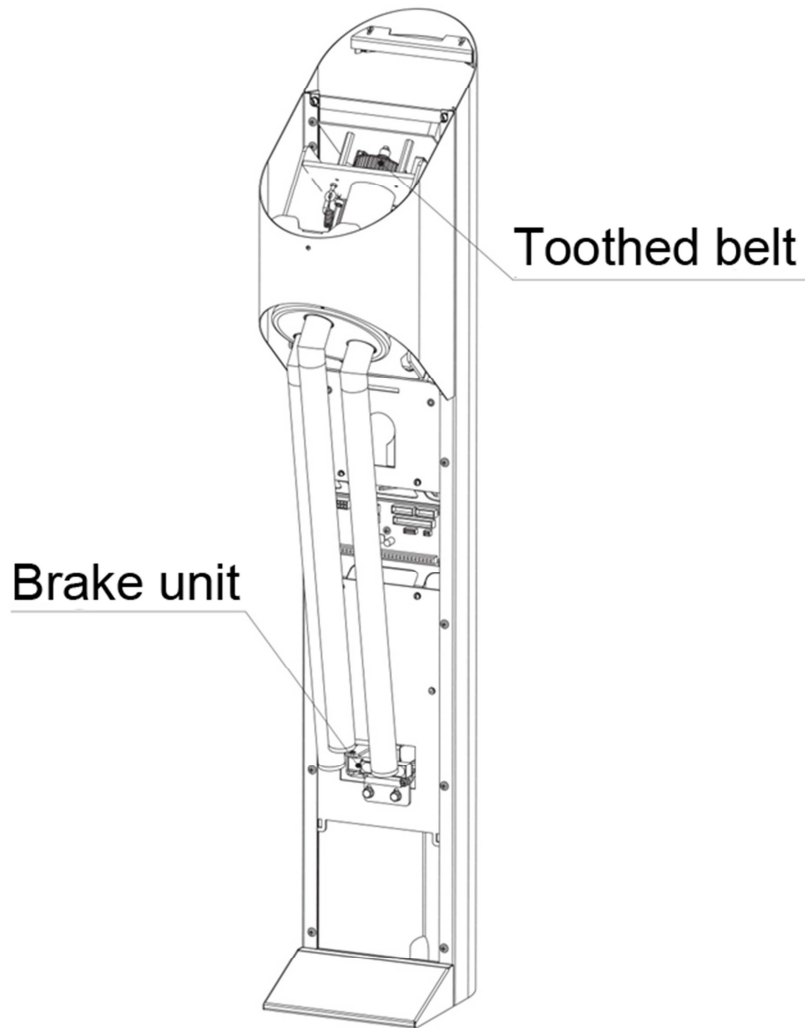


*Fig. 10 Central stand of turnstile*

#### 4. Checking turnstile parts

- 4.1. Clean the load-bearing frame from contamination.
- 4.2. Check that all cables are securely connected.
- 4.3. If necessary check and tighten the screw joints of turnstile:
- 4.4. Check the condition of the toothed belt and its tension (Fig. 11).
- 4.5. Check the general condition of the rubber plate stopper unit (Fig.

11).



*Fig. 11(central stand of turnstile)*

## 5. Lubrication of moving parts

Lubrication is made with 2 - 3 drops of engine oil (viscosity grade 5W-20).

5.1. The rotation axis of the stopper unit (Fig. 12).

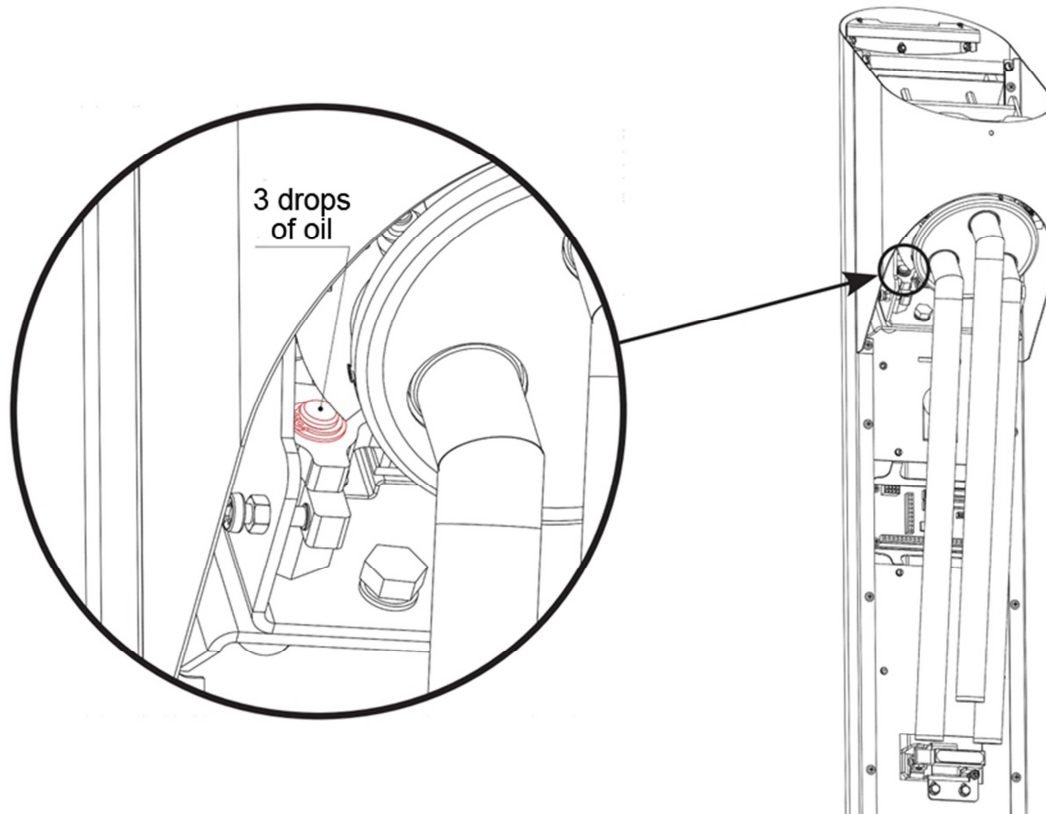
5.2. The rotation axis of the roller lever (Fig. 13).

5.3. Clip between the stopper unit and the solenoid (Fig. 14).

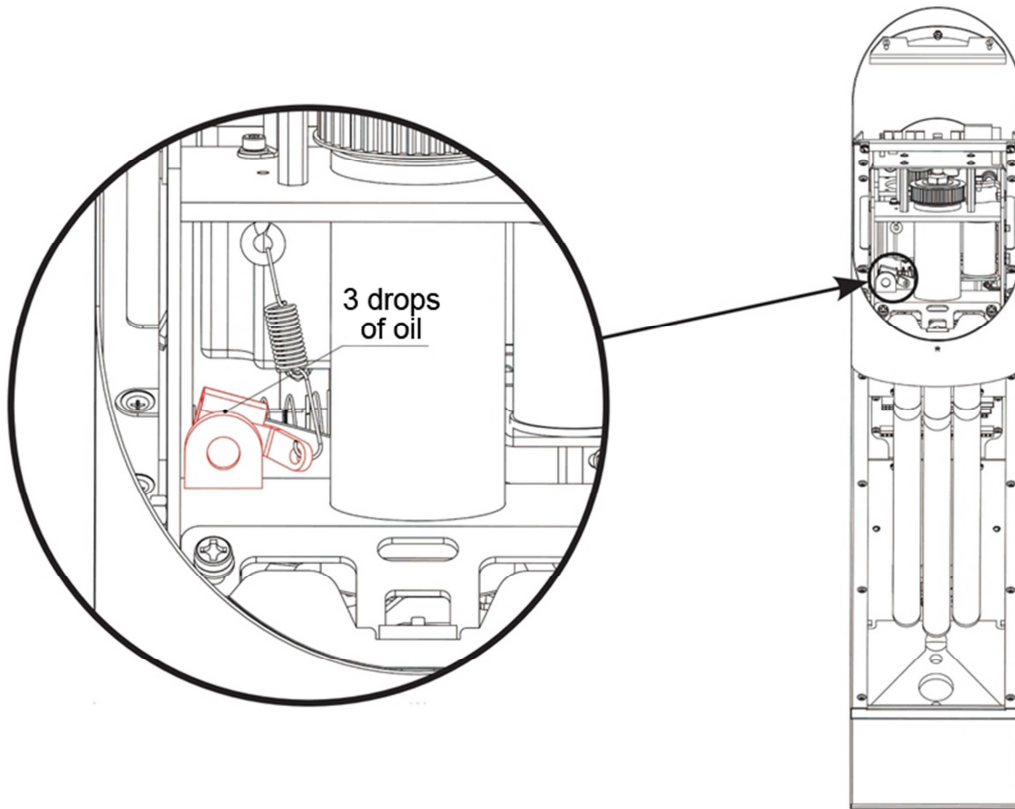
Elements of the unit are located behind the roller lever shown on Fig. 13

5.4. The rotation axis of unlocking arms cam (Fig. 15).

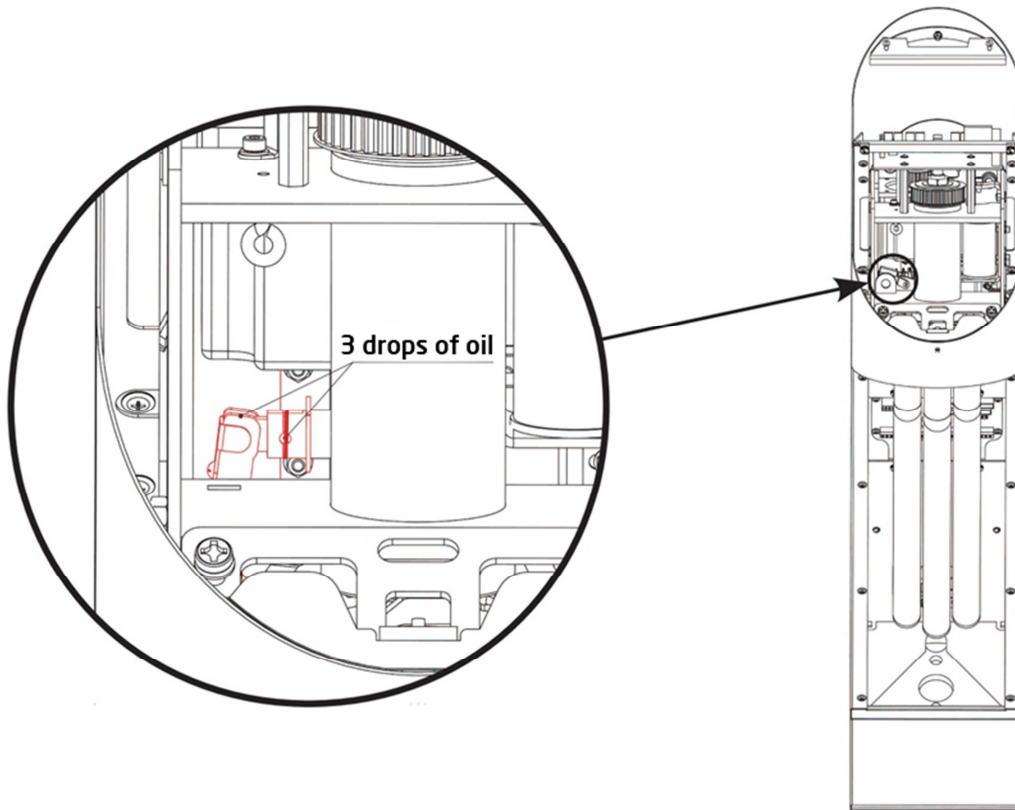
5.5. The connection of lock pin and arms-unblocking cams (Fig. 16). The operation shall be done for each arm by rotating the disc. Hole in Fig. 16 is shown in the conventional manner.



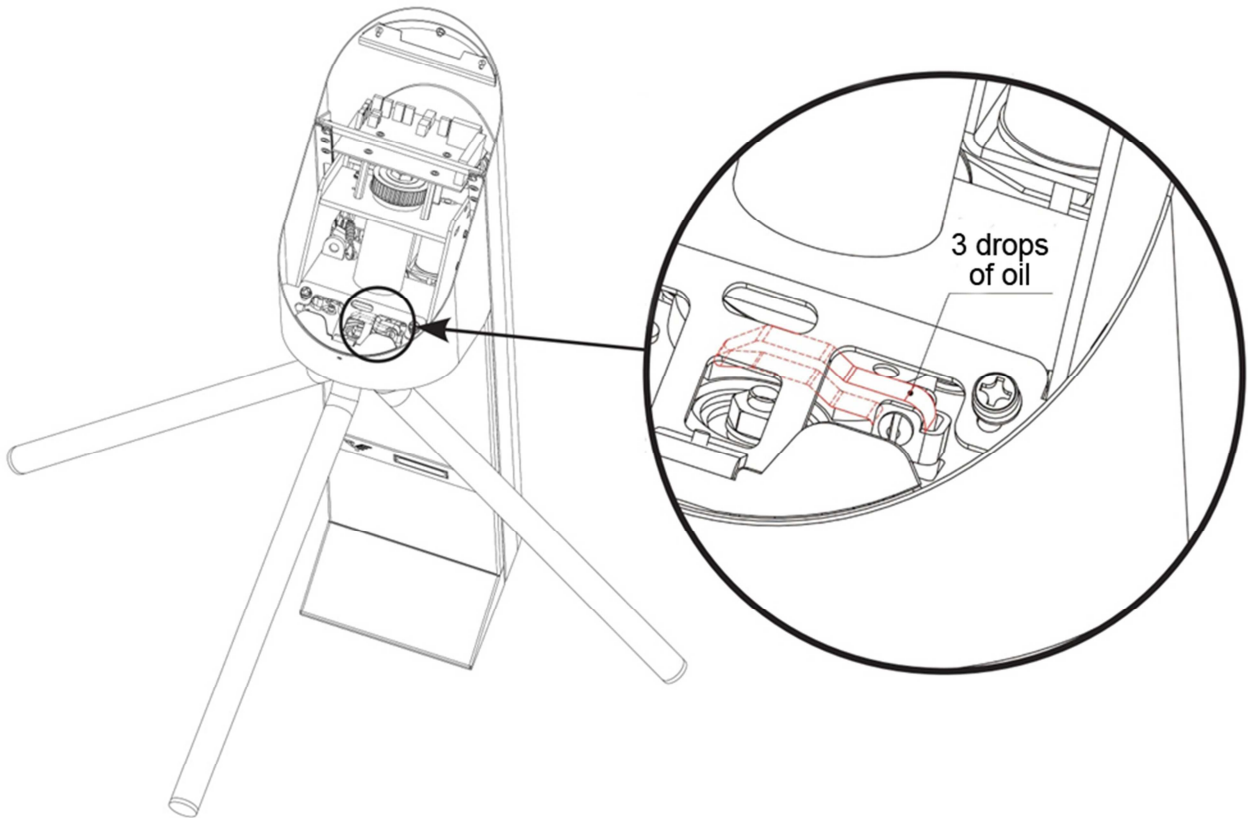
*Fig. 12 Central stand of turnstile*



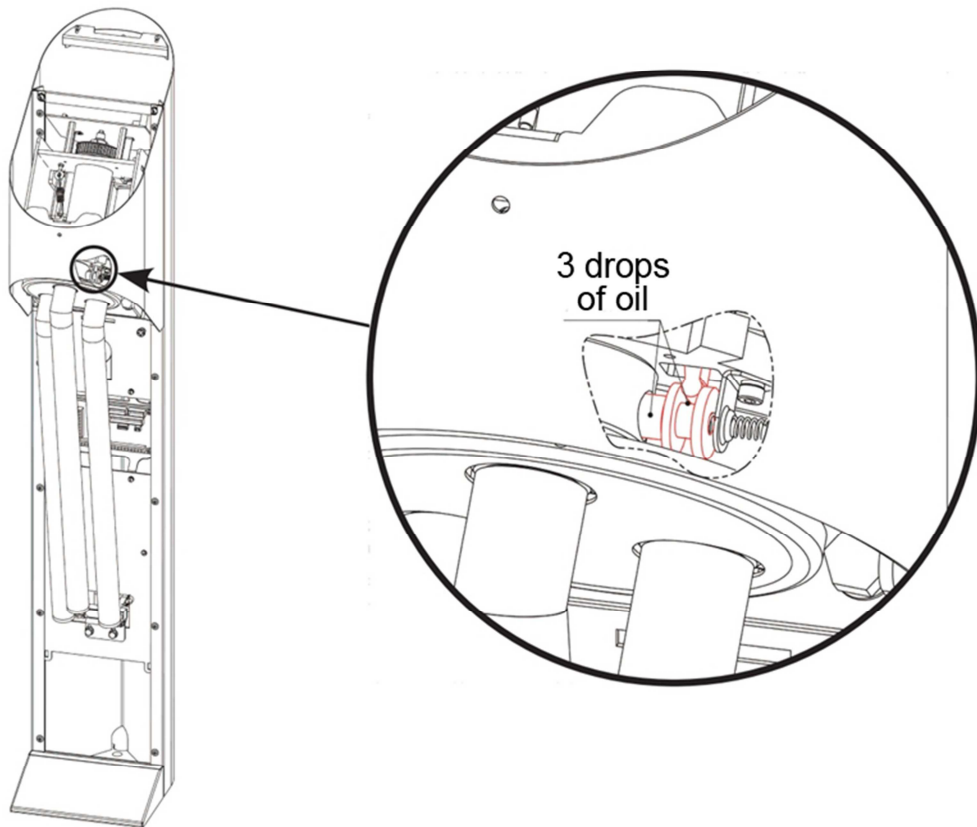
*Fig. 13 Central stand of turnstile*



*Fig. 14 Central stand of turnstile*



*Fig. 15 Central stand of turnstile*



*Fig. 16 Central stand of turnstile*



## **6. Assembling and performance checking of the turnstile**

6.1. If any troubles or defects are found out during MO it is advised to contact our service department for advice, contact details are available online:

[www.oxgard.com](http://www.oxgard.com)

6.2. If it is necessary to repair damaged painted surfaces, powder paint identical to the damaged (RAL9005) shall be used in accordance with instructions for its use.

6.3. Reassemble the turnstile in reverse order.

6.4. Turn on the turnstile and perform functionality check by making several passes and activating “antipanic” mode.

6.5. If there is no extraneous noise or any abnormality in the turnstile work it is ready for operation.







ООО "Vozrozhdenie"

192289 Saint Petersburg

Sofiyskaya st., 66

Tel./fax +7 (812) 366 15 94

[www.oxgard.com](http://www.oxgard.com)

[info@oxgard.com](mailto:info@oxgard.com)

